

06020

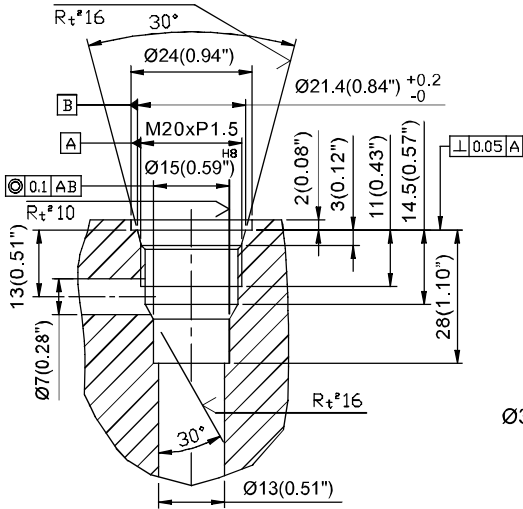

CSE04-2N

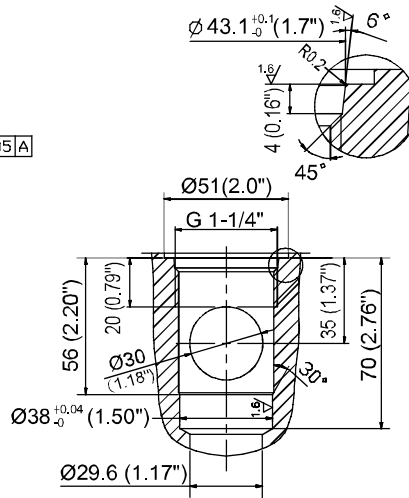

CSE017-2N

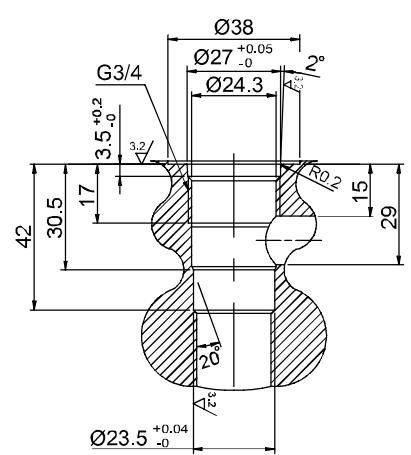

CSE019-2N

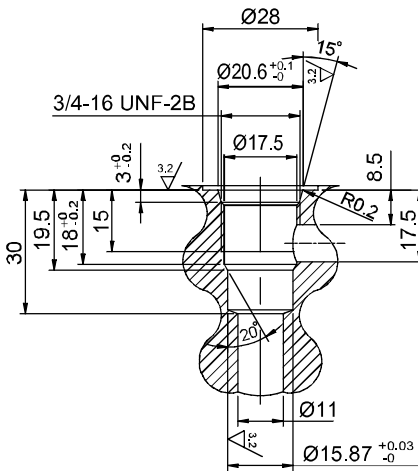

CSE021-2N

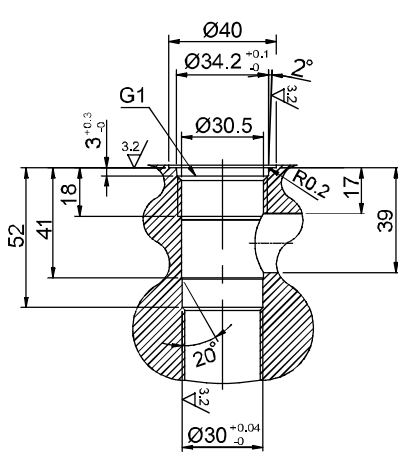

CS04-B3

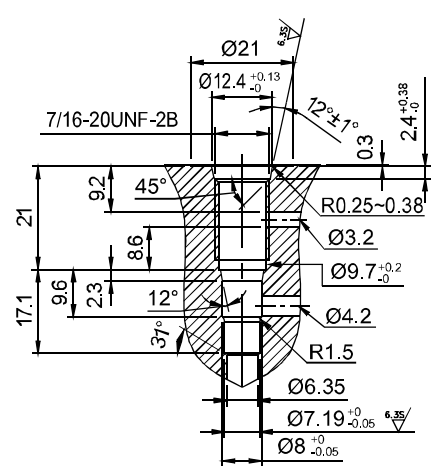

CS08-2N

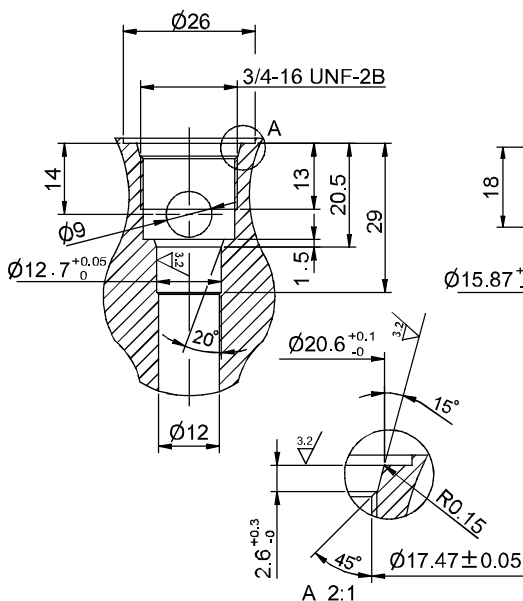

CS10-2N

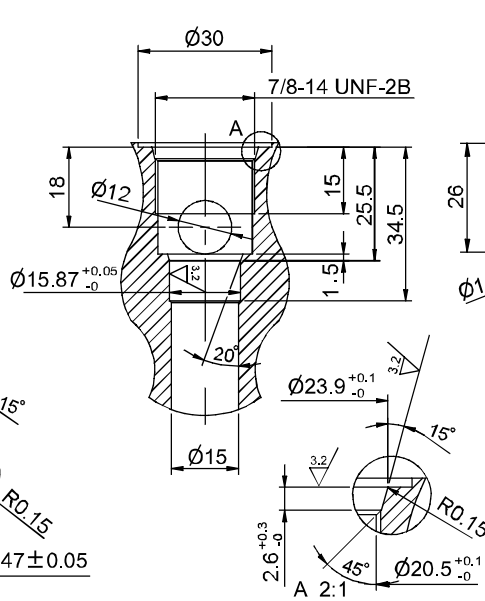

CS12-2N

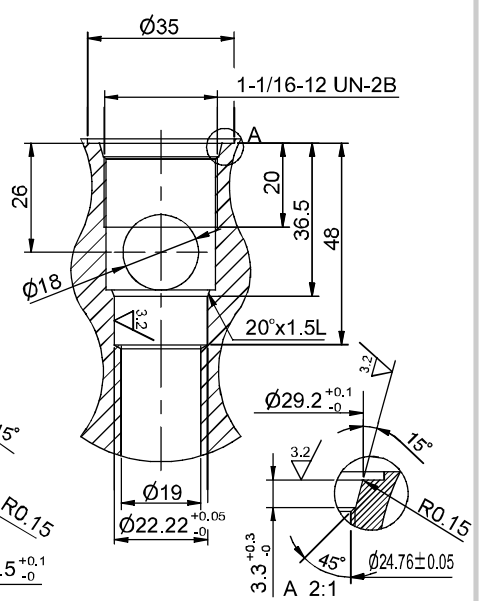

* Recommended tap drill size just for reference. 螺紋分下孔徑尺寸僅供參考。

CS16-2N

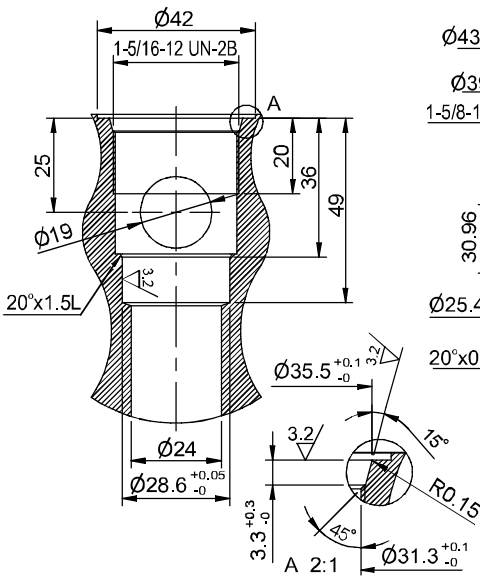

CS20-2N

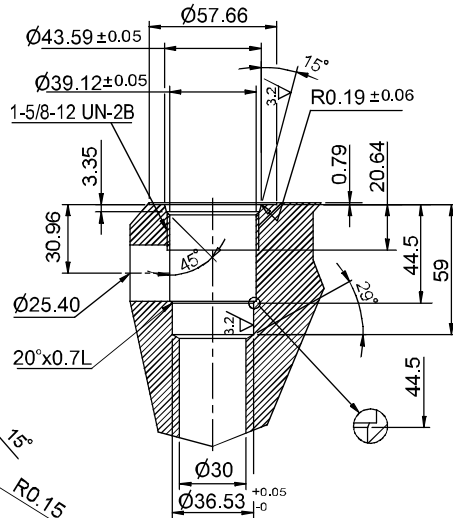

CS42-2N

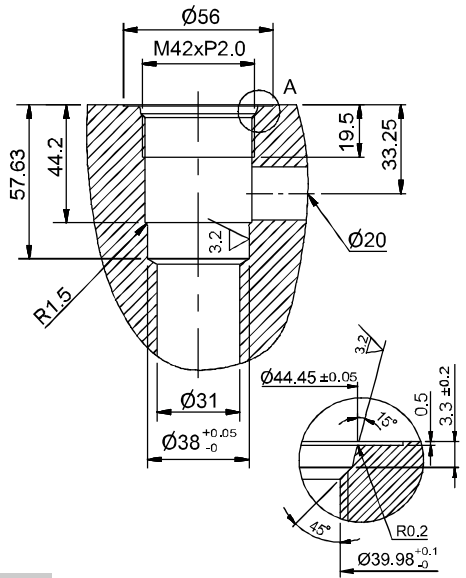

CS08-3N

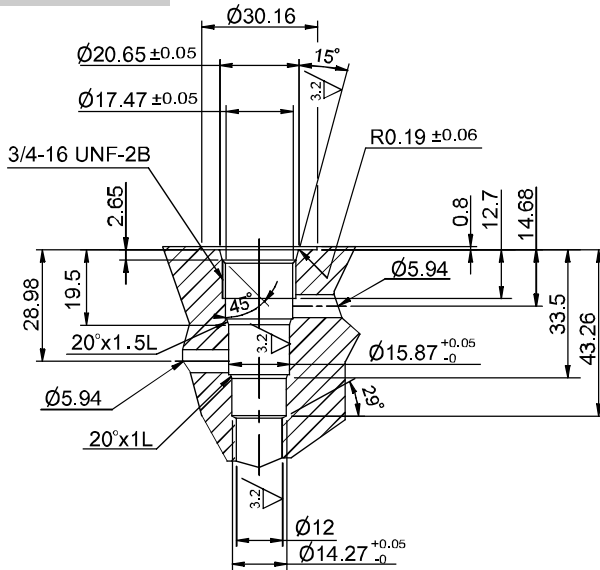

CS10-3N

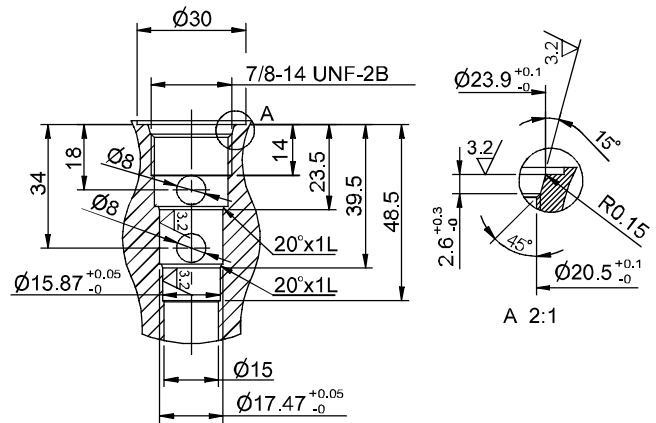

CS12-3N

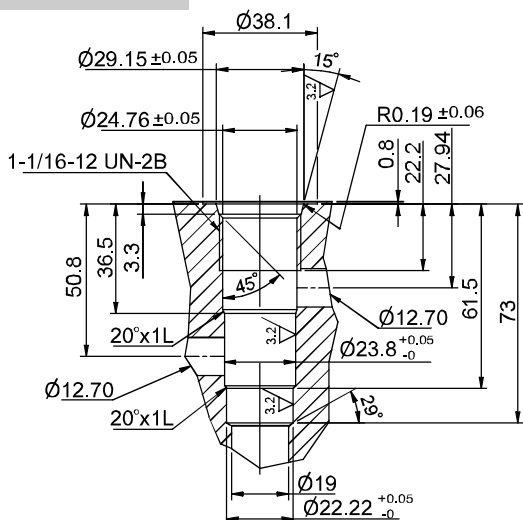

CS16-3N

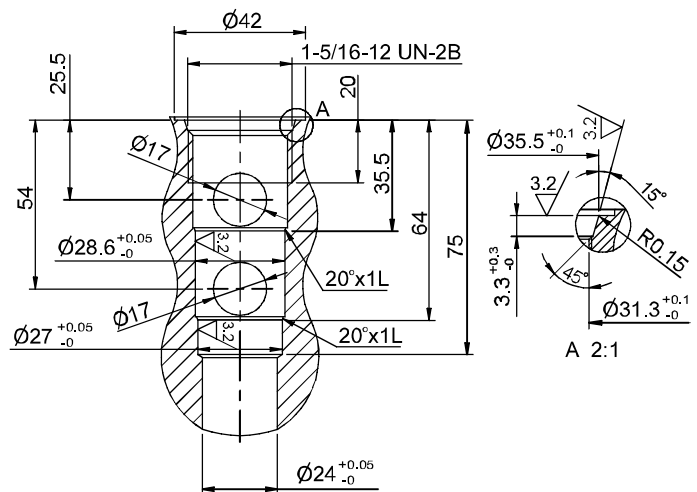

CS20-3N

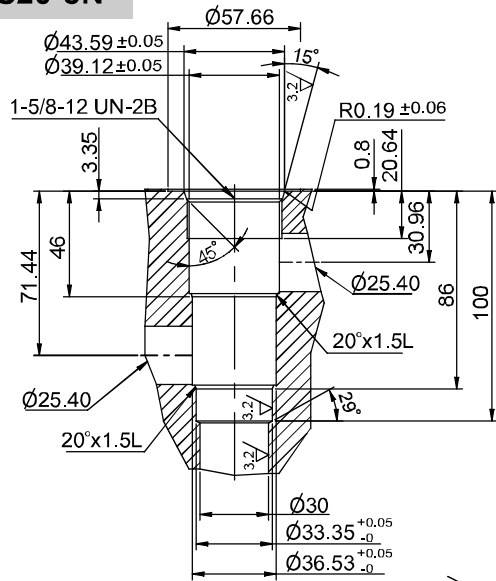

CS08-3S

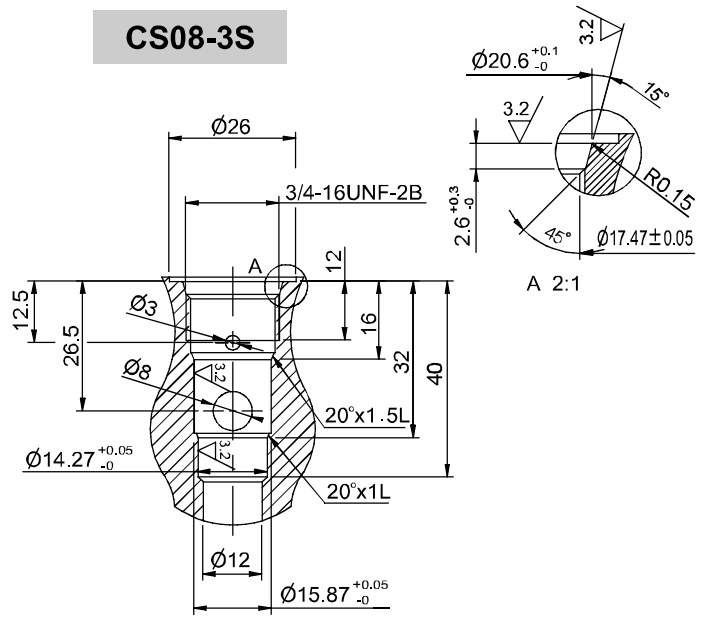

CS10-3S

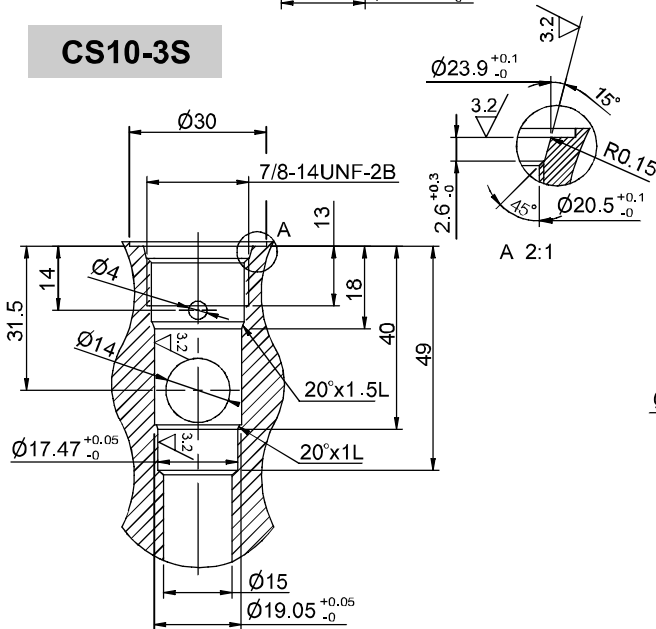

CS12-3S

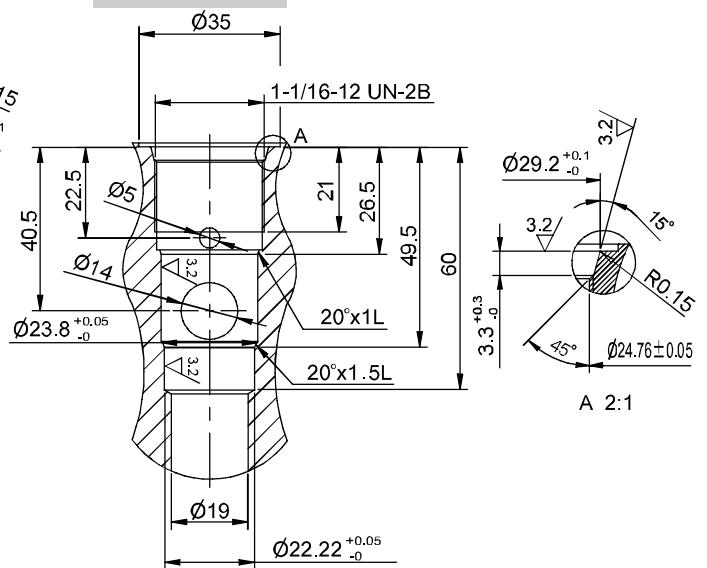

CS16-3S

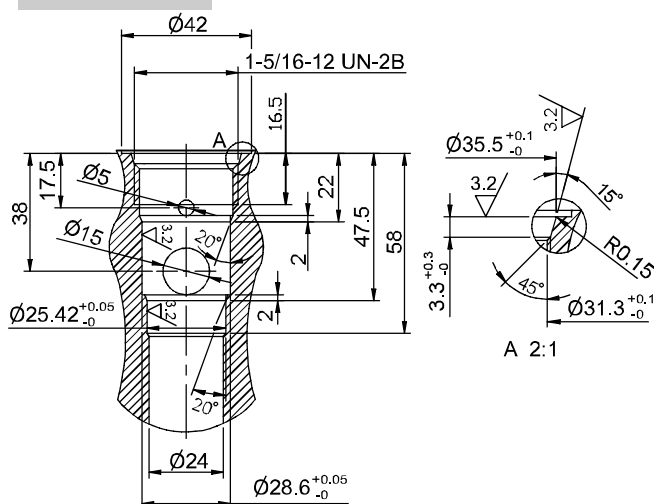

CS20-3S

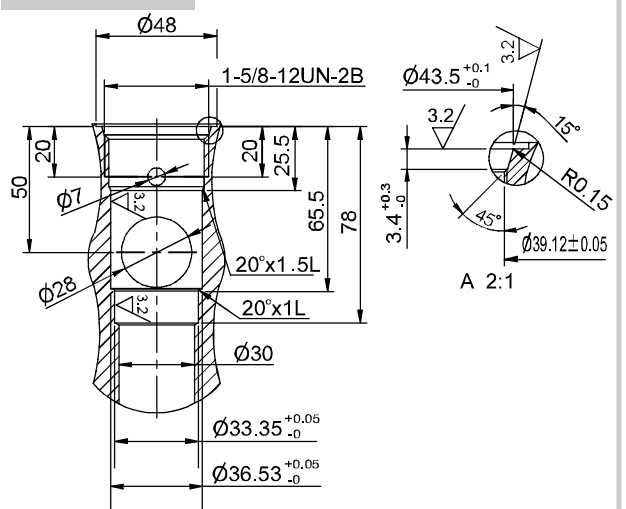

* Recommended tap drill size just for reference.
 螺紋分下孔徑尺寸僅供參考。

CS08-4N

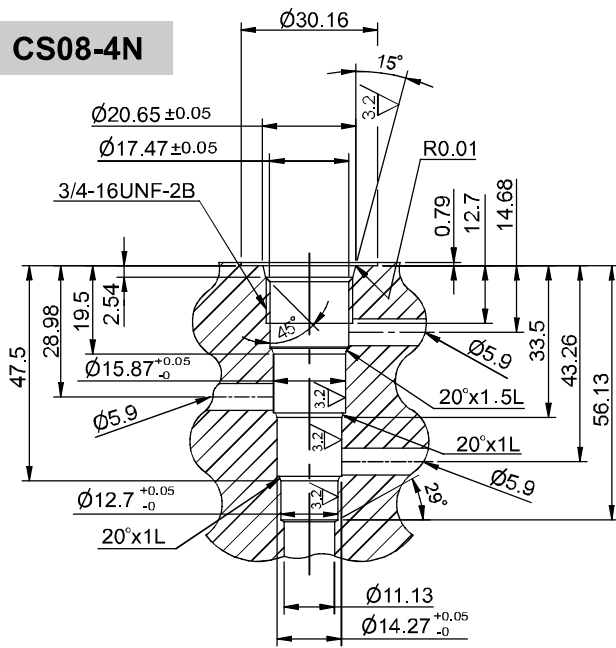

CS10-4N

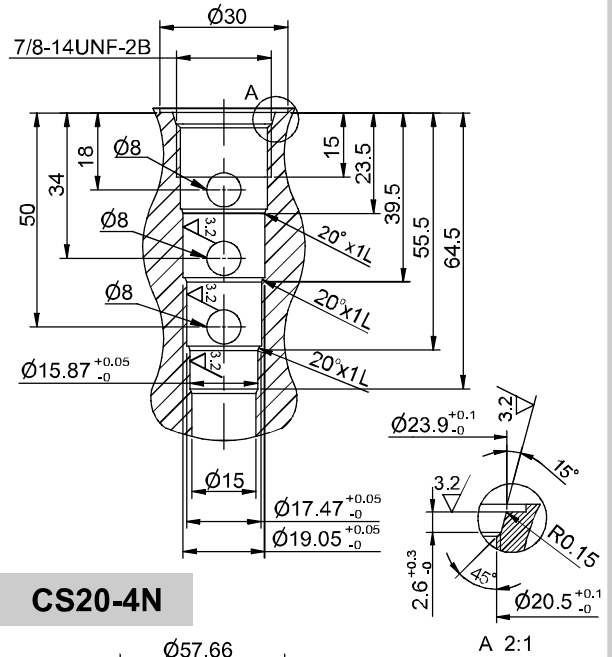

CS12-4N

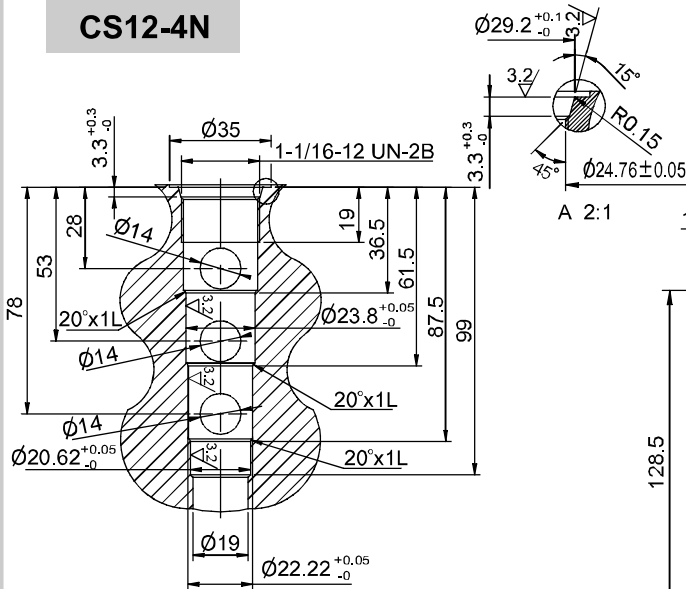

CS20-4N

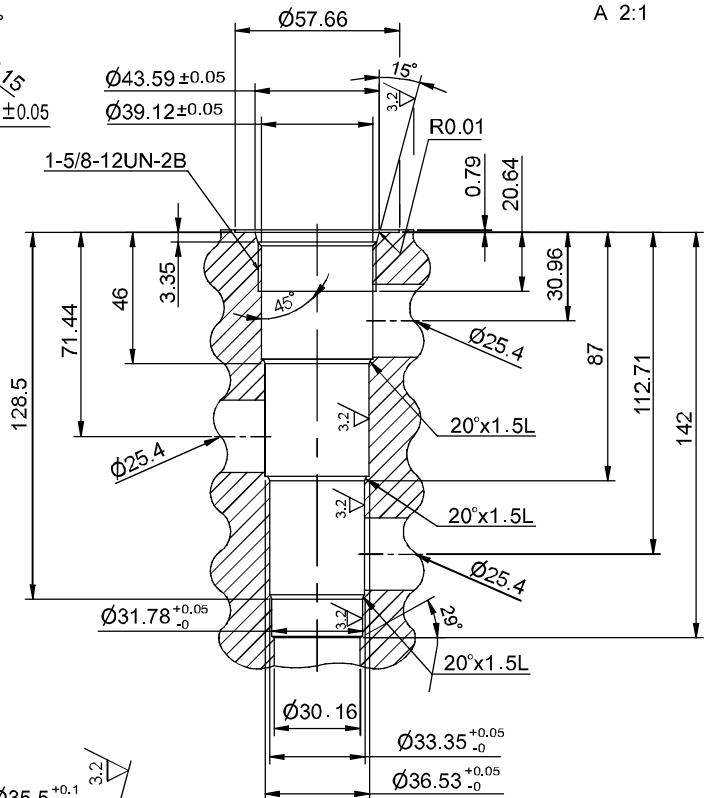

CS16-4N

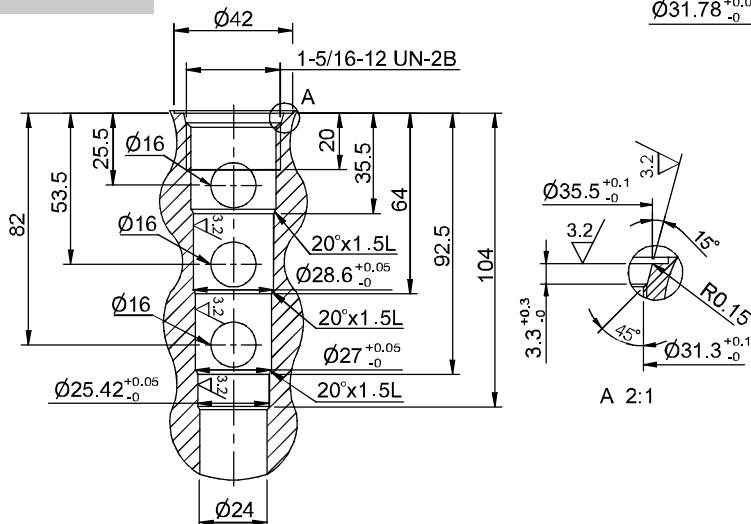

CS10A-4N

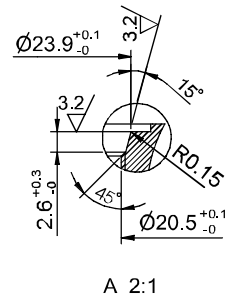
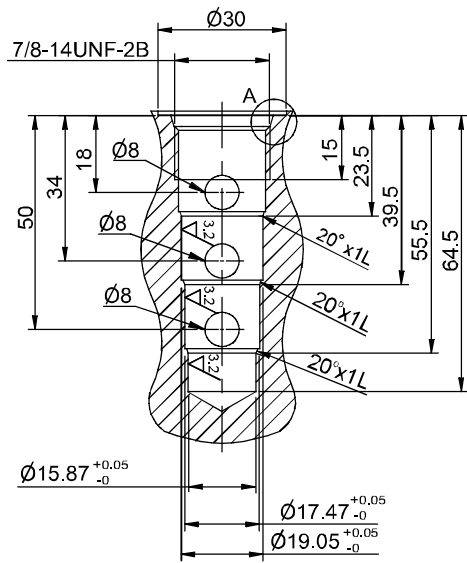

CS12A-4N

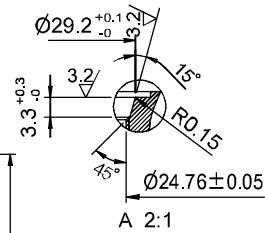
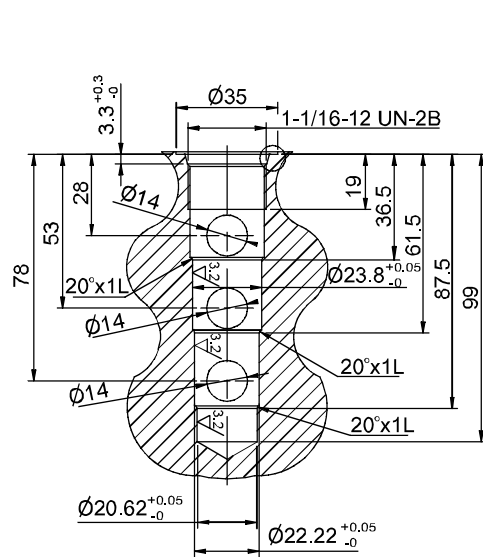

CS16A-4N

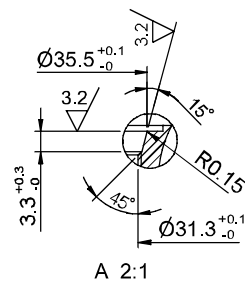
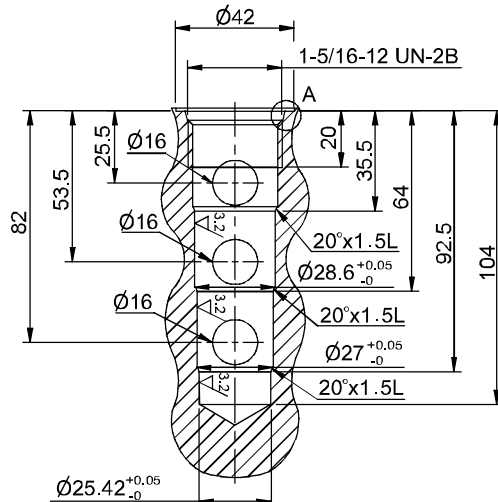

* Recommended tap drill size just for reference.
 螺紋牙下孔徑尺寸僅供參考。

CST-2A

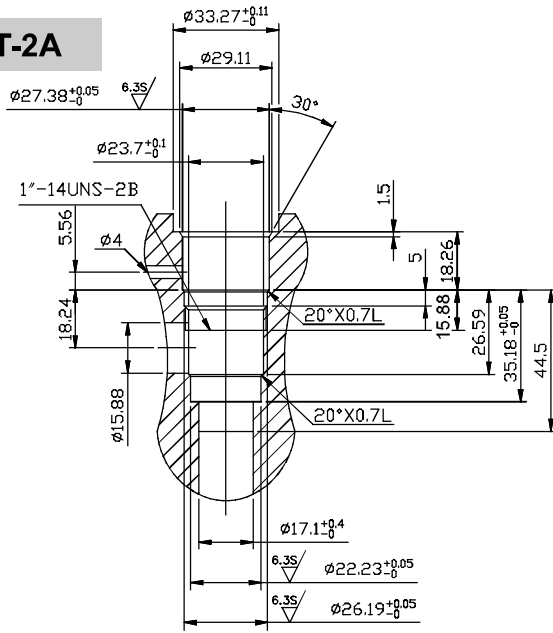

CST-3A

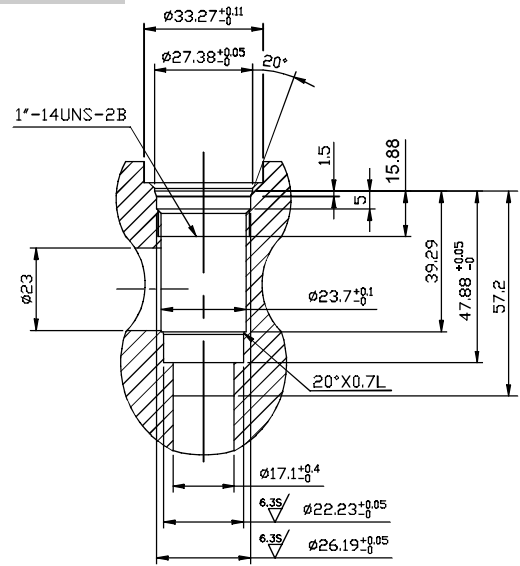

CST-5A

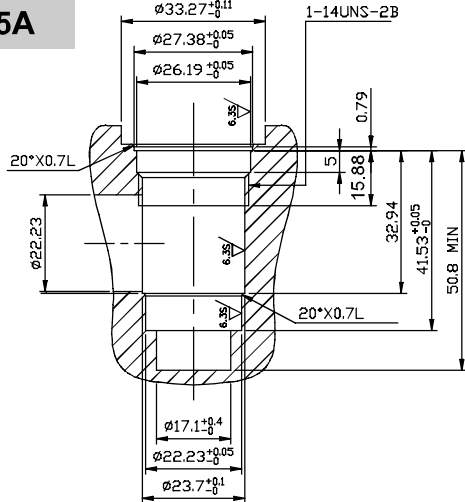

CST-10A

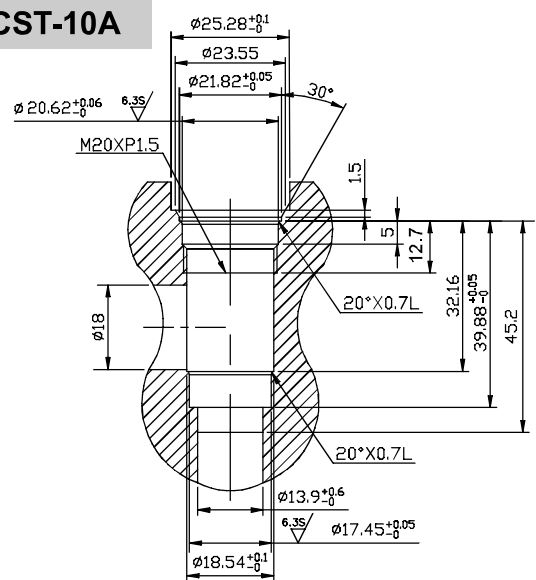

CST-11A

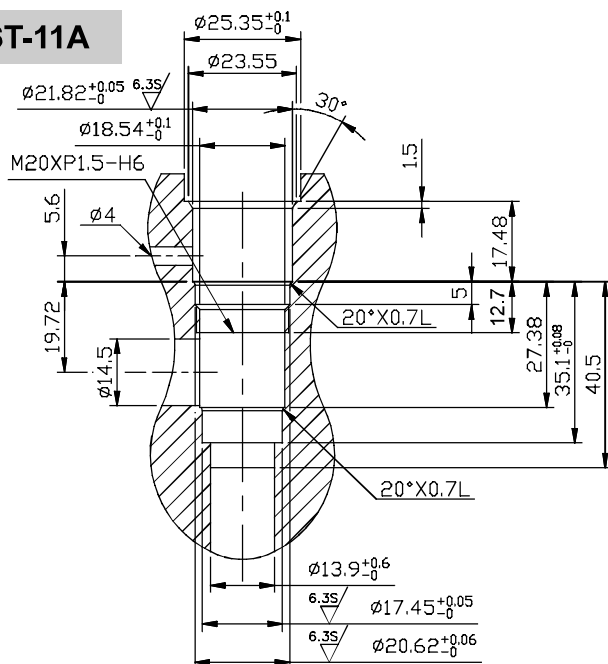

CST-13A

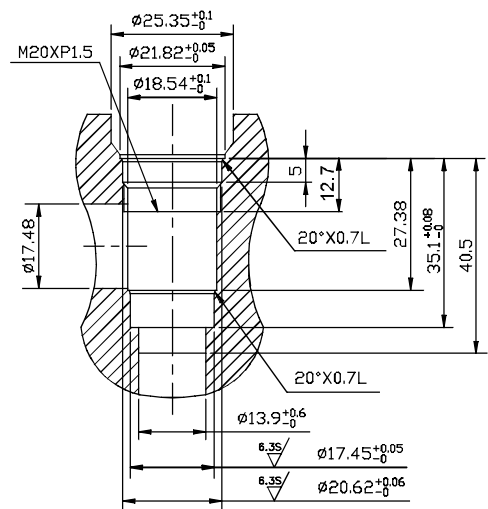

CST-16A

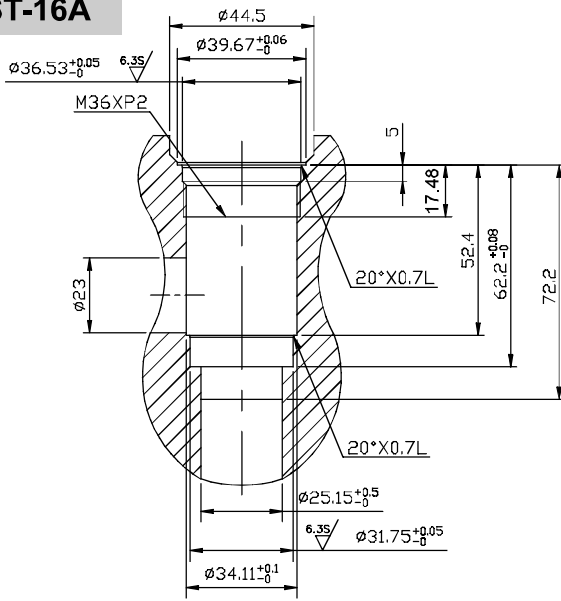

CST-17A

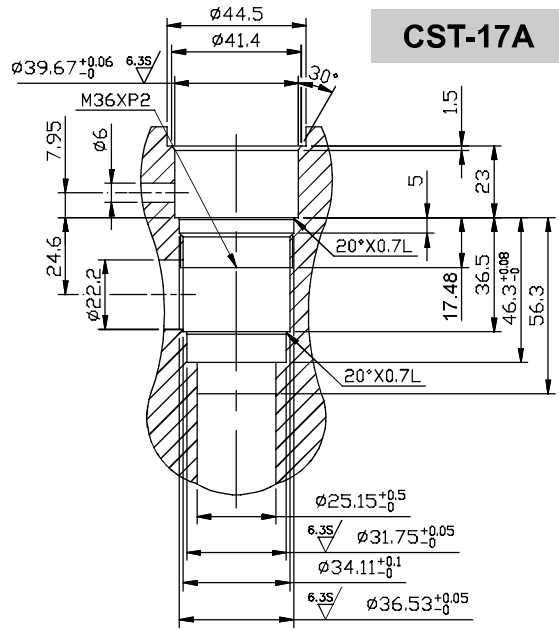

CST-18A

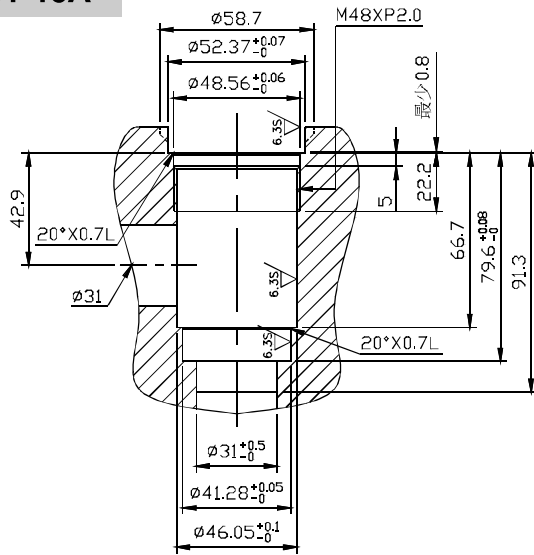

CST-19A

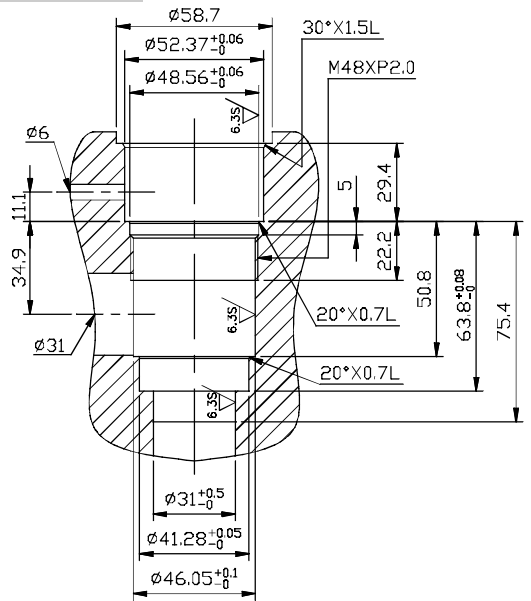

CST-8A

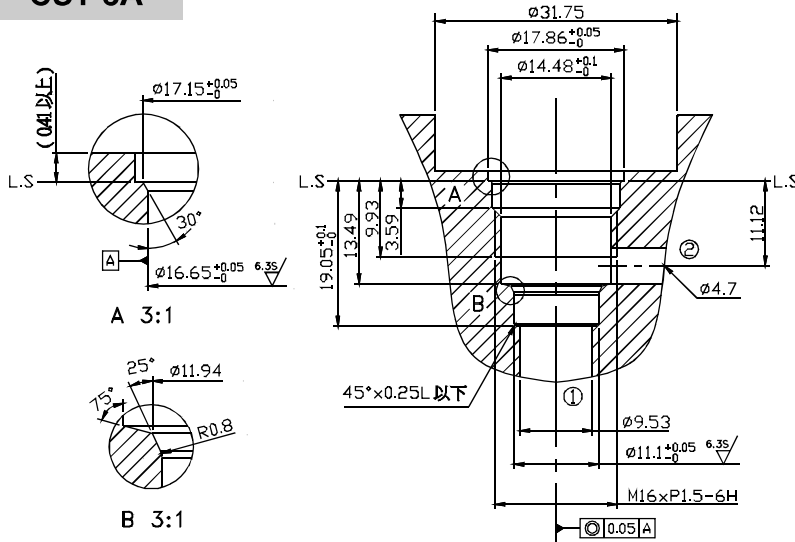

* Recommended tap drill size just for reference.
 螺紋分下孔徑尺寸僅供參考。

CST-63A

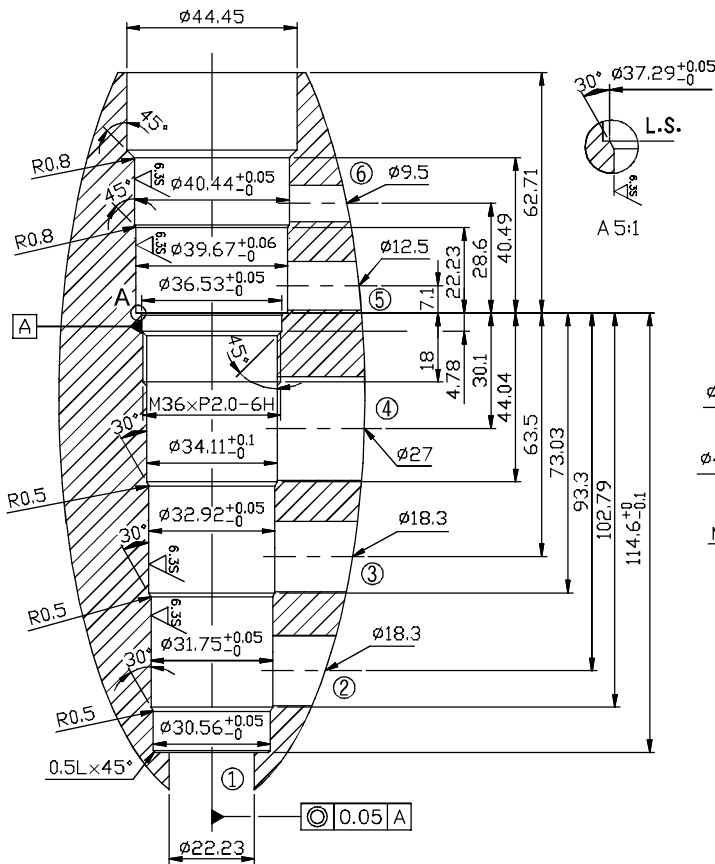

CST-64A

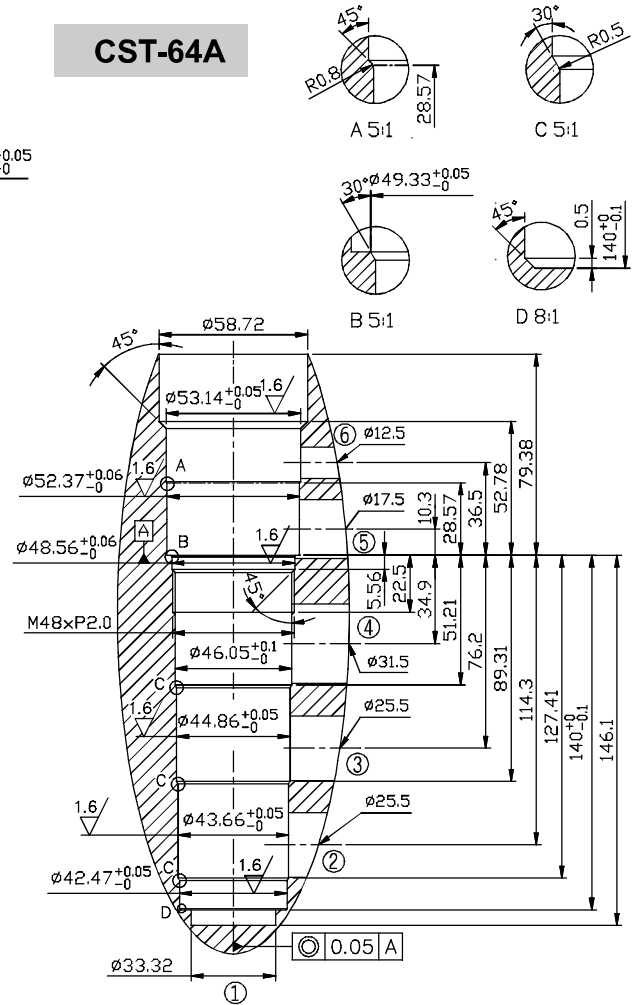

CST-162A

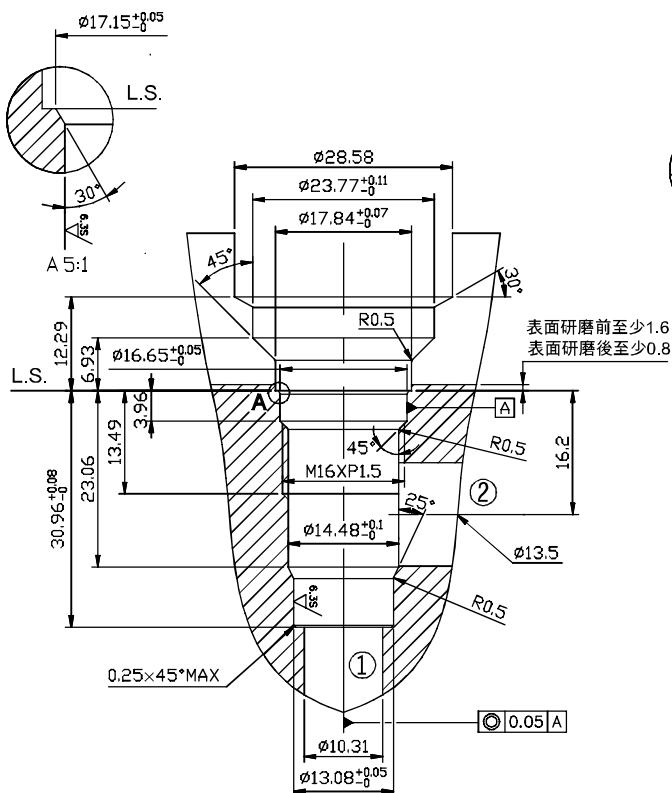

CST-163A

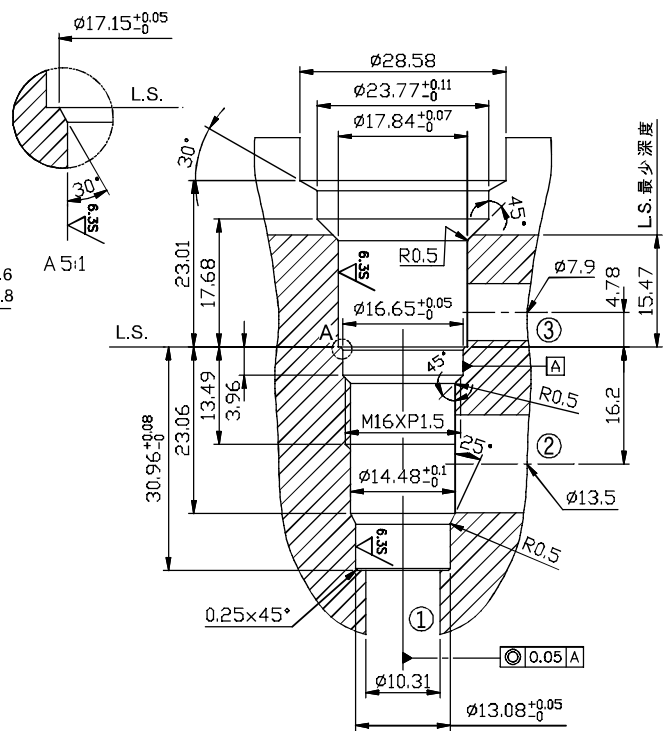

CST-21A

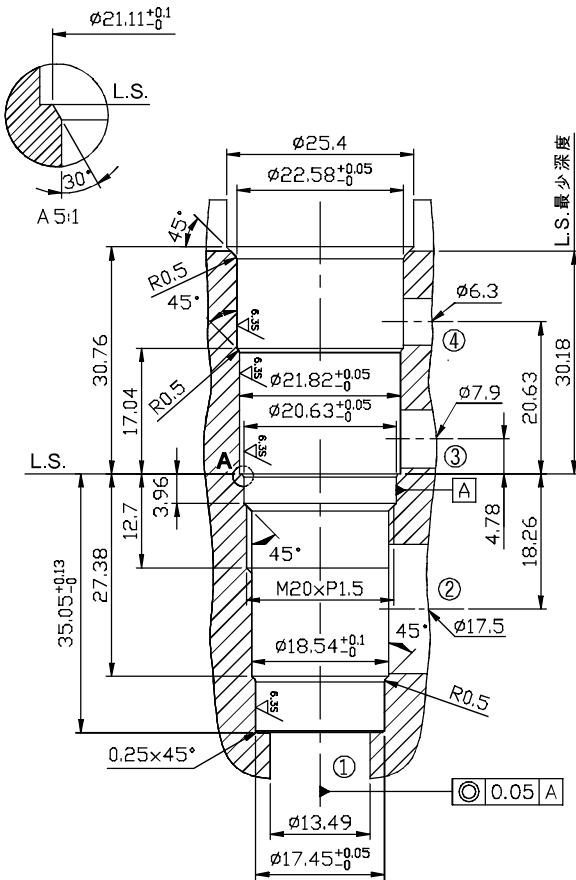

CST-22A

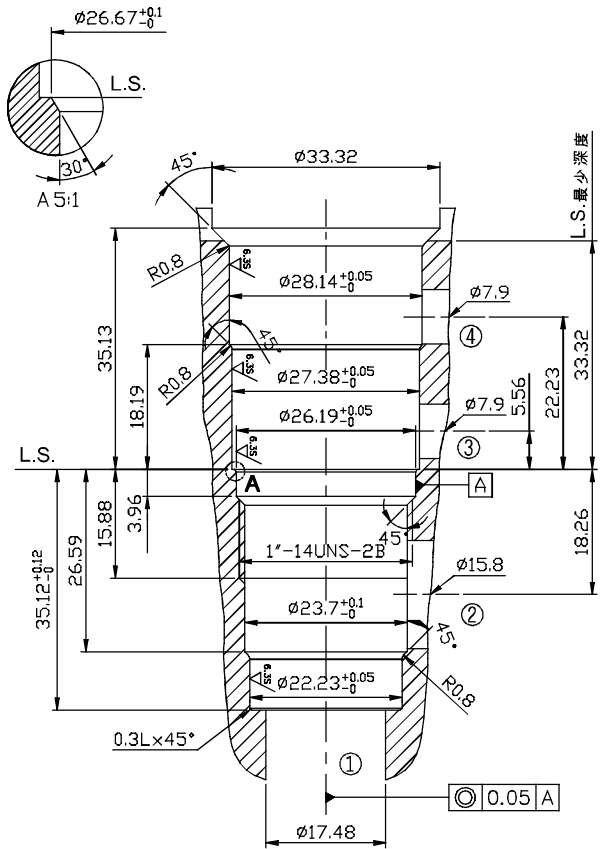

CST-23A

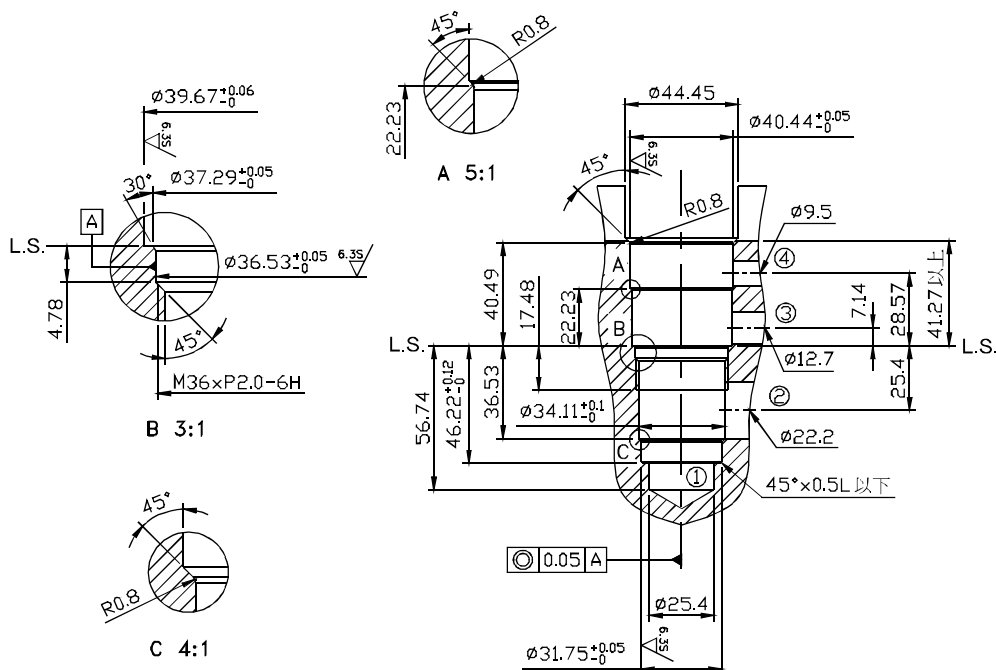

* Recommended tap drill size just for reference.
 螺紋牙下孔徑尺寸僅供參考。

CST-24A

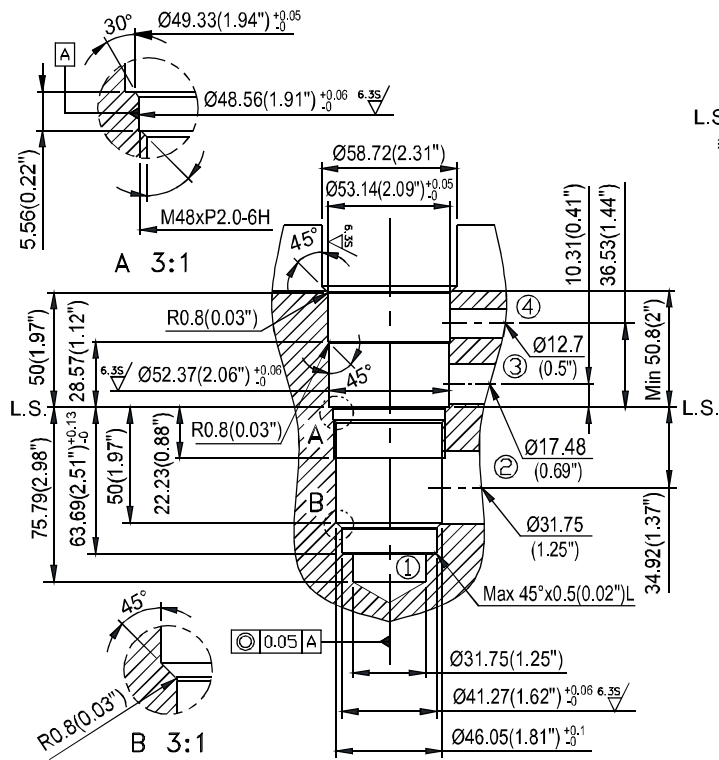

CST-9A

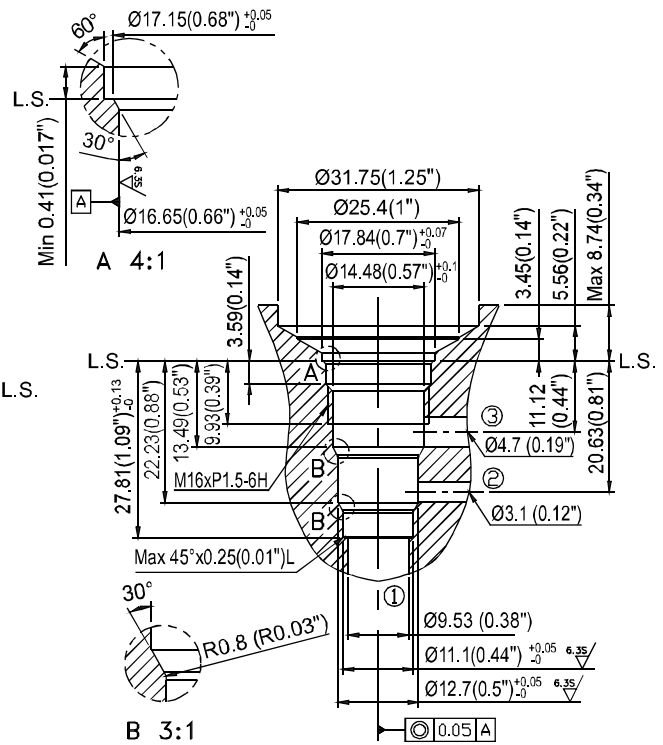

CST-18AU

