

◆ MODEL 型 式

MRB-03G



◆ FEATURES

- MRB series modular balance valves are proper and excellent for the hydraulic assembly of the spindle head off working machine.
 - Casting iron valve bodies are provide strength and durability for longer life.
 - Internal hardened steel components also provide longer life.
 - Two flow adjustment options are: hex. screw or knob.
- 特 點
 - MRB 系列稱量型平衡閥為工作母機主軸頭油壓配量，提供良好的閥件。
 - 鑄本體結構強度均自耐久性，壽命長。
 - 內部硬鋼零件提高壽命。
 - 六角螺絲或把手兩種流量調整選擇。

◆ SPECIFICATIONS 規 格

Model Number 型式號碼	Maximum Pressure 最大壓力 bar	Connecting PT 適用管徑	Maximum Flow 最大流量 lpm	Weight 重量 Kg
MRB-02G-A	250 (3625 PSI)	1/4"	30 (7.93 GMP)	1.5 (3.3 lbs)
MRB-03G-A		3/8"	50 (13.2 GMP)	3.5 (7.7 lbs)
Fluid Type 液體型式			ISO VG 32, 46, 68	
Viscosity 黏性 cSt			10-400 (59-1854 SSU)	
Operating Temperature 操作溫度 °C			-15-70 (-5-158°F)	
Contamination Level 污染標準			ISO4406. 21/19/16 NAS1638,10	
Surface Treatment 表面處理			Zinc Phosphate Compound 鋅磷酸化合物	

- All screws with metric measure, if require inch measure, please contact us.
所有螺絲皆為公制標準規格品，若需英制螺絲請另外備註說明。

◆ HOW TO ORDER 編號說明

1	2	3	4	5	6
MRB	02	G	A	*	20

1 VALVE SERIES 系列名稱

MRB=Balancing Modular Valves
(Pressure Reducing and Relief Valve)

2 SUBPLATE MOUNTING SIZE: 稱厚口徑

02 = 1/4"(6mm) 03 = 3/8"(9mm)
ISO CETOP3 ISO CETOP5
DIN NG 6 DIN NG 10
NFPA D03 NFPA D05

3 CONNECTING TYPE 連接型式

C:TYPE:BASEPLATE MOUNTING TYPE
(板式連接)

4 CONTROL PORT(S) 動作形式

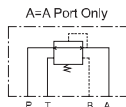

5 ADJUSTMENT PRESSURE 壓力調整範圍

02 | 1. 8~70 (bar) 03 | 1. 8~70 (bar)
2. 8~140 (bar) 2. 8~140 (bar)
3. 10~210 (bar) 3. 10~210 (bar)

6 DESIGN NO 設計編號

◆ PERFORMANCE 性能

Test Conditions 測試條件

Oil Temperature 油溫度: 50°C(122°F)

Viscosity 黏度: 35 cSt (163 SSU)

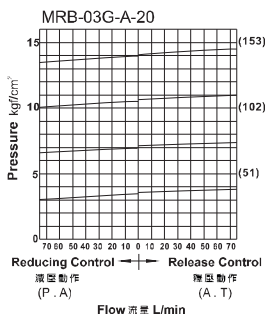
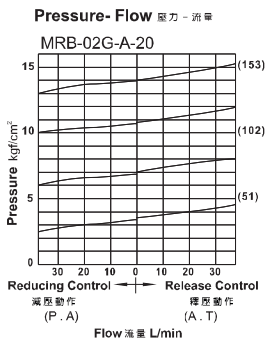

Setting Pressure - Flow 設定壓力 - 流量

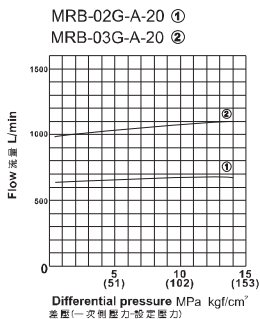

BALANCING MODULAR VALVES(Pressure Reducing and Relief Valve)

MRB SERIES

稱量型平衡閥

◆ DIMENSIONS 外型尺寸圖

MRB-02G

4 - 5.7 (0.22") ϕ Drilled
 $\phi 9$ (0.35") Countersink hole, depth5

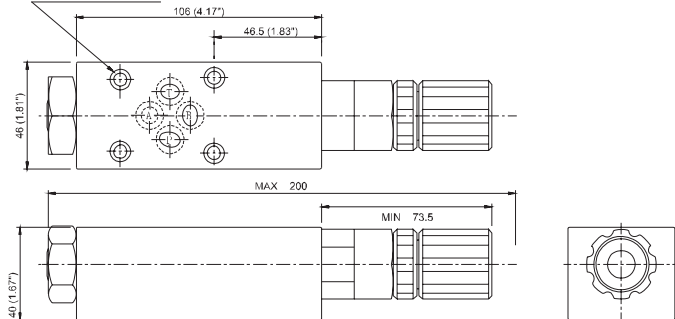

◆ Mounting Interface 基準尺寸圖

ISO 4401-AB-03-4-A

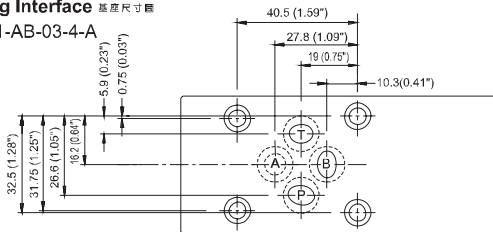

◆ PARTS LIST OF MRB-02G

零件爆炸视图

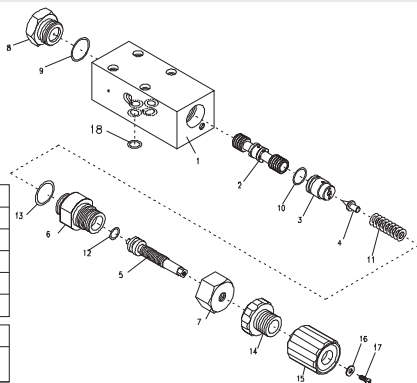

SEAL KITS 密封配件

NO	Description	Q'ty	Specification
9	O-ring	1	P20
10	O-ring	1	P12.5
12	O-ring	1	P10
13	O-ring	1	P18
18	O-ring	4	P9

MRB-02G-A G TYPE (板式連接)

HEX COUNTER-SINK SCREW 圓錐六角螺絲	4	M5 x 40L
----------------------------------	---	----------

BALANCING MODULAR VALVES(Pressure Reducing and Relief Valve)

積層型平衡閥

MRB SERIES

◆ DIMENSIONS 外型尺寸圖

MRB-03G

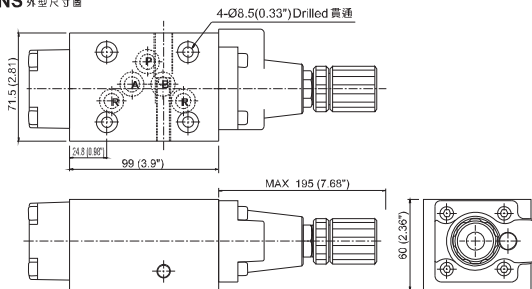

◆ Mounting Interface 基座尺寸圖

ISO 4401-AC-05-4-A

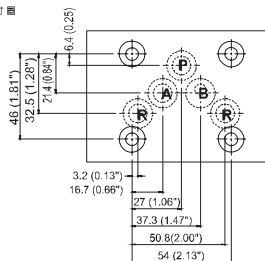

◆ PARTS LIST OF MRB-03G

零件爆炸視圖

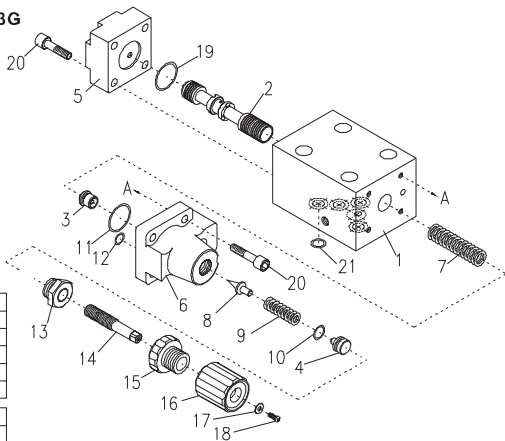

◆ SEAL KITS 密封配件

NO	Description	Qty	Specification
10	O-ring	1	P9
11	O-ring	1	P22
19	O-ring	1	P22
12	O-ring	1	P8
21	O-ring	5	P12

MRB-03G-A G TYPE (G 式連接)			
HEX COUNTER-SINK SCREW 六角六角螺絲	4	M8 x 30L	

E
MRB