

SOLENOID CONTROLLED RELIEF VALVES

電磁式溢流閥

SRV SERIES

MODEL 型式

SRV-03G, 06G, 10G-50



CONTROL PORT(S) 動作形式

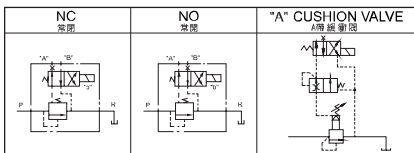

- Apply Electric Symbol the Pump can be Loading Out.
- Apply Pilot Operated Relief Valves and The Hydraulic System to obtained two kind of pressure control.
- 利用電氣符號使油壓機載荷卸載。
- 利用先導式溢流閥、使液壓系統得到兩種控制方式。

SPECIFICATIONS 規格

Model Number 型式號碼	Maximum Pressure 最大壓力 bar	Connecting PT 適用管徑	Maximum Flow 最大流量 lpm	Weight 重量 Kg
SRV-03G-★-50	250 (3625 psi)	3/8"	100 (26.42 gpm)	6.1 (13.4 lbs)
SRV-06G-★-50		3/4"	200 (52.84 gpm)	7.4 (16.3 lbs)
SRV-10G-★-50		1-1/4"	400 (105.678 gpm)	12.9 (28.4 lbs)
Fluid Type 液體型式			ISO VG 32, 46, 68	
Viscosity 黏性 cSt			10-400 (59-1854 SSU)	
Operating Temperature 操作溫度 °C			-15-70 (-5-158 °F)	
Contamination Level 污染標準			ISO4406, 21/19/16 NAS1638,10	

● All screws with metric measure, if require inch measure, please contact us.

所有螺絲皆為公制標準規格者，若需英制螺絲請另洽確認說明。

HOW TO ORDER 編號說明

1	2	3	4	5	6	7	8	9	10	
SRV	A	03	G	3	L	★	★	20	50	★

1 VALVE SERIES 系列名稱

SRV=Solenoid Controlled Relief Valves

2 CUSHION VALVE 緩衝閥

NONE: None Cushion Valve (Standard)

無不帶緩衝閥(標準型)

A: With Cushion Valve (anyone)

See Control Port(s)

A:帶緩衝閥(任選)及動作形式

3 SUBPLATE MOUNTING SIZE: 稱呼口徑

03 = 3/8"(9mm)

06 = 3/4"(19mm)

ISO CETOP5

ISO CETOP8

DIN NG 10

DIN NG 25

NFPA D05

NFPA D08

10 = 1 1/4"(31.8mm)

ISO CETOP10

DIN NG 32

NFPA D10

4 CONNECTING TYPE 連接型式

G:TYPE:BASEPLATE MOUNTING TYPE (板式連接)

5 ADJUSTMENT PRESSURE 壓力調整範圍

1. ★ - 70 bar 2. 8 - 140 bar 3. 8 - 250 bar

6 ORIENTATION 調整方向

NONE T ORIENTATION (Standard) 無: T方向(標準型)

L P ORIENTATION L: P方向

7 COIL TYPES OF SOLENOID VALVE

電磁閥電壓種類型

A1: AC110 A2: AC220

D1: DC12 D2: DC24

R1: RF110 R2: RF220

8 WIRING TYPE 線路型式

20: WIRING BOX TYPE 線路盒式

30: DIN TYPE DIN型

9 DESIGN NO 設計編號

50: low noise, pressure regulating valve

90型 低噪音溢流閥

10 CONTROL TYPE 控制方式

NONE: Normally Open (NO). None pressure_ under

electric power off. (Standard)

無常開(NONE) 不通電時無壓力(標準型)

NC: Normally Close. Pressure raise_ under electric

power off

NC 常閉 不通電時壓力上升

SOLENOID CONTROLLED RELIEF VALVES

SRV SERIES

電磁式溢流閥

DIMENSIONS 外形尺寸圖

SRV-03G. 06G. 10G-50

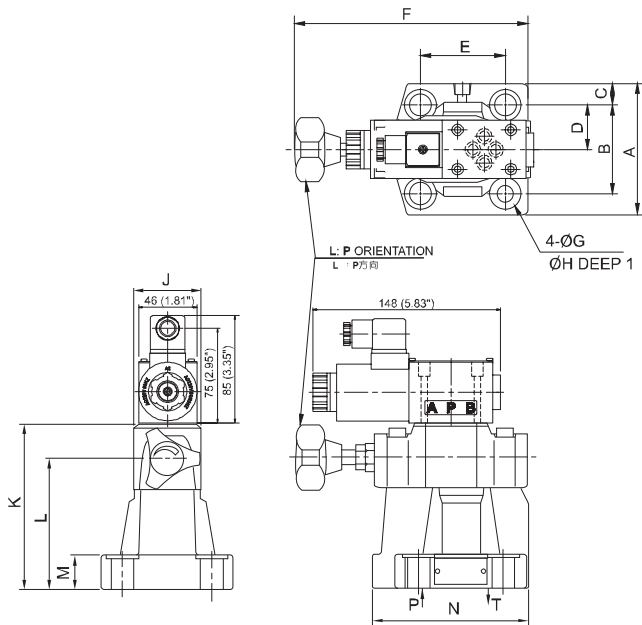

ACCESSORIES 附屬配件			
SRV-03G-50	HEX. COUNTER-SINK SCREW	4	M12 x4L
SRV-06G-50	HEX. COUNTER-SINK SCREW	4	M16 x50L
SRV-10G-50	HEX. COUNTER-SINK SCREW	4	M20 x 60L

MODEL	A	B	C	D	E	F
SRV-03G-50	76(2.99")	53.8(2.12")	11.1(0.44")	26.9(1.06")	53.8(2.12")	171(6.73")
SRV-06G-50	104(4.09")	70(2.76")	17(0.67")	35(1.38")	66.7(2.63")	171(6.73")
SRV-10G-50	120(4.72")	82.6(3.25")	18.7(0.74")	41.3(1.63")	88.9(3.50")	188(7.40")

MODEL	G	H	J	K	L	M	N
SRV-03G-50	13.5(0.53")	21(0.83")	51(2.0")	132(5.20")	104(4.09")	22(0.87")	106(4.17")
SRV-06G-50	17.5(0.69")	25(0.98")	51(2.0")	132(5.20")	104(4.09")	27(1.06")	123(4.84")
SRV-10G-50	21.5(0.85")	32(1.26")	65(2.56")	167(6.57")	135(5.31")	33.5(1.32")	155(6.10")