

# PRESSURE REDUCING & CHECK VALVES

(單向)減壓閥

BRVC SERIES

## ◆ MODEL 型 式

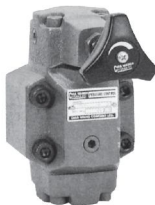

BRVC-03G SERIES



BRVC-03T SERIES

## ◆ SPECIFICATIONS 規 格

Model Number 型式號碼	Maximum Pressure 最大壓力 bar	Connecting PT 適用管徑	Maximum Flow 最大流量 lpm	Weight 重量 Kg
BRV-02G	250 (3625 psi)	1/4"	40 (10.57 gpm)	1.3 (2.9 lbs)
BRV-03G				4.8 (10.6 lbs)
BRV-03T				4.6 (10.1 lbs)
BRVC-03G		3/8"	50 (13.20 gpm)	5.5 (12.1 lbs)
BRVC-03T				4.8 (10.6 lbs)
BRV-06G				6.9 (15.2 lbs)
BRV-06T		3/4"	125 (33.02 gpm)	7.4 (16.3 lbs)
BRVC-06G				8.5 (18.7 lbs)
BRVC-06T				8.5 (18.7 lbs)
BRV-10G		1 1/4"	250 (66.04 gpm)	12 (26.5 lbs)
BRV-10T				13.4 (29.5 lbs)
BRVC-10G				14.5 (32.0 lbs)
BRVC-10T	15.5 (34.2 lbs)			
Fluid Type 液體型式		ISO VG 32, 46, 68		
Viscosity 黏性 cSt		10~400 (59~1854 SSU)		
Operating Temperature 操作溫度 °C		-15~70 (-5~158 °F)		
Contamination Level 污染標準		ISO4406. 21/19/16 NAS1638,10		

◆ All screws with metric measure, if require inch measure, please contact us. 所有螺絲皆為公制標準規格者。若需英制螺絲請另備註說明。

## ◆ HOW TO ORDER 編號說明

1	2	3	4	5	6
BRV	*	03	G	1	30

- 1 VALVE SERIES 系列名稱**  
 BRV= Pressure Reducing  
 BRVC= Pressure Reducing & Check Valves

- 2 CHECK VALVE 止逆閥**  
 C: Include Check Valve C: 附止逆閥

- 3 SUBPLATE MOUNTING SIZE: 稱呼口徑**  
 03 = 3/8"(9mm) ISO CETOP5 DIN NG 10 NFPA D05  
 06 = 3/4"(19mm) ISO CETOP8 DIN NG 25 NFPA D08  
 10 = 1 1/4"(31.8mm) ISO CETOP10 DIN NG 32 NFPA D10

- 4 CONNECTING TYPE 連接型式**  
 T:TYPE:THREADING TYPE (螺紋連接)  
 G:TYPE:BASEPLATE MOUNTING TYPE (板式連接)

- 5 PRESSURE ADJUSTMENT 壓力調整範圍**  
 1. 5 - 70 bar 2. 8 - 140 bar  
 3. 8 - 250 bar

- 6 DESIGN NO 設計編號**

### ◆ CONTROL PORT(S) 動作形式

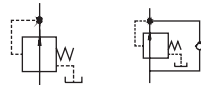

**F**  
BRVC

# PRESSURE REDUCING & CHECK VALVES

## BRVC SERIES

(單向)減壓閥

### ◆ PERFORMANCE 性能

Test Conditions 測試條件

Oil Temperature 油溫: 50°C(122°F)

Viscosity 黏度: 35 cSt (163 SSU)

#### BRVC-03

##### Reverse Pressure Drop (Free Flow)

反向壓力降 (自由流量)

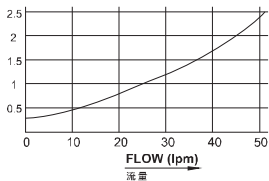

#### BRVC-10

Pressure Drop (bar)

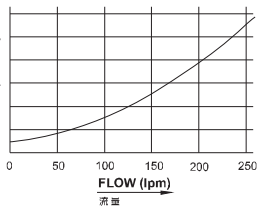

#### BRVC-06

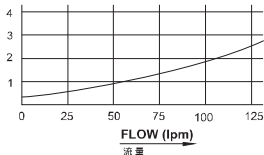

### ◆ ACCESSORIES (G TYPE) 附屬配件(板式連接)

MODEL NUMBER	HEX. COUNTER-SINK SCREW
BRV-02G-30	M5 x 40L (4pcs)
BRV-03G	M10 x 55L (4pcs)
BRVC-03G	M10 x 85L (4pcs)
BRV-06G	M10 x 55L (4pcs)
BRVC-06G	M10 x 85L (4pcs)
BRV-10G	M10 x 65L (6pcs)
BRVC-10G	M10 x 105L (6pcs)

### ◆ SECTION 剖面圖

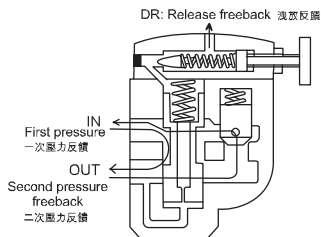

### ◆ DIMENSIONS 外型尺寸圖

#### BRV-02G

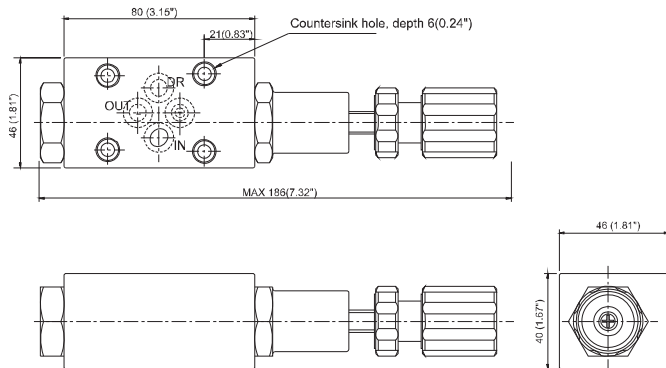

### ◆ Mounting Interface 基座尺寸圖

#### ISO 4401-AB-03-4-A

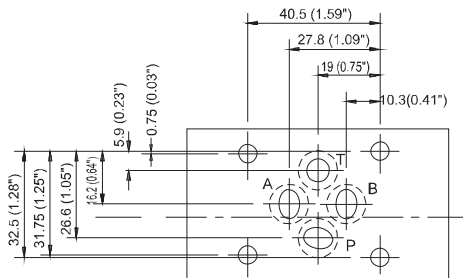

# PRESSURE REDUCING & CHECK VALVES

## BRVC SERIES

(单向) 减压阀

### ◆ DIMENSIONS 外形尺寸图

#### BRVC-03. 06. 10G

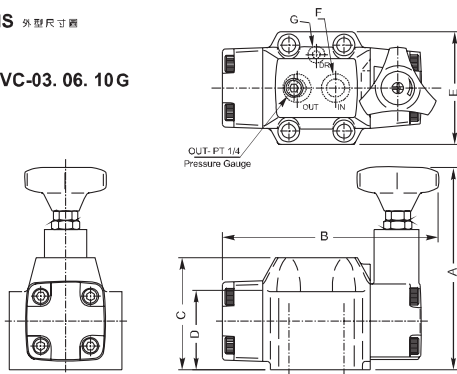

MODEL 型号	A	B	C	D	E	F	G
BRVC-03G	166(6.54")	165(6.50")	90(3.54")	61(2.40")	90(3.54")	P18	P10
BRVC-06G	166(6.54")	179(7.05")	108(4.25")	69(2.72")	102(4.02")	P28	P10
BRVC-10G	164(6.46")	229(9.02")	130(5.12")	82(3.23")	119(4.69")	P40	P10

#### BRVC-03. 06. 10T

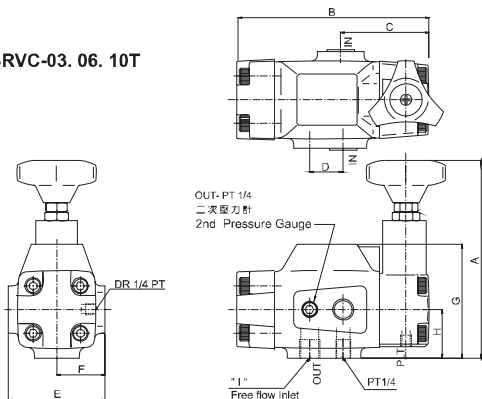

MODEL 型号	A	B	C	D	E	F	G	H	I
BRVC-03T	165(6.50")	158(6.22")	73(2.87")	26(1.02")	78(3.07")	39(1.54")	92(3.62")	38.5(1.52")	PT3/8
BRVC-06T	162(6.38")	184(7.24")	80(3.15")	36(1.42")	97(3.82")	48.5(1.91")	118(4.65")	49.5(1.95")	PT3/4
BRVC-10T	182(7.17")	221(8.70")	87(3.43")	49(1.93")	132(5.20")	66(2.60")	152(5.98")	66.7(2.63")	PT 1-1/4

# PRESSURE REDUCING & CHECK VALVES

(单向) 减压阀

BRVC SERIES

## ◆ DIMENSIONS 外型尺寸圖

### BRV-03. 06. 10G

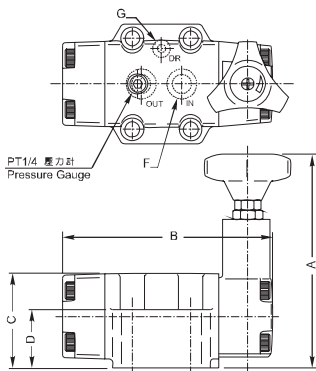
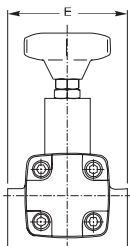

MODEL 型 式	A	B	C	D	E	F	G
BRV-03G	164(6.46")	158(6.22")	70(2.76")	42(1.65")	87(3.43")	P18	P10
BRV-06G	170(6.69")	185(7.28")	83(3.27")	42(1.65")	100(3.94")	P28	P10
BRV-10G	174(6.85")	220(8.66")	94(3.15")	48(1.89")	120(4.72")	P40	P10

● The install size of valve please refer the base seat drawing of type SVM-03. 06. 10

(注) 請參閱圖號SVM-03.06.10的安裝尺寸圖

### BRV-03. 06. 10T

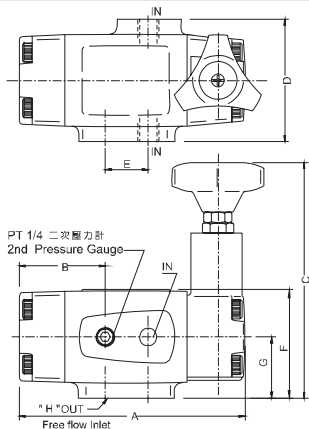
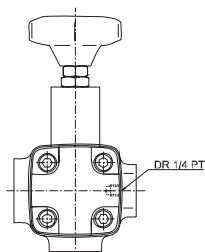

MODEL 型 式	A	B	C	D	E	F	G	H
BRV-03T	158(6.22")	57(2.24")	162(6.38")	82(3.23")	28(1.10")	74(2.91")	40.5(1.59")	PT 3/8
BRV-06T	184(7.24")	66(2.6")	161(6.34")	87(3.43")	34.5(1.36")	96(3.78")	48(1.89")	PT 3/4
BRV-10T	221(8.70")	75(2.95")	178(7.01")	132(5.19")	48(1.89")	109(4.29")	63.5(1.59")	PT 1-1/4