

# CAM OPERATED DIRECTIONAL VALVES

凸輪行程換向閥

DCG SERIES

## ◆ MODEL 型 式

**DCG-2B2-02G-10**



**DCG-2B2-02G-20**



## ◆ SPECIFICATIONS 規 格

Model Number 型式號碼	Maximum Pressure 最大壓力 bar	Connecting PT 適用管徑	Maximum Flow 最大流量 lpm	Weight 重量 Kg
DCG-2B2-02G-20	315 (4500 psi)	1/4"	30 (7.93 gpm)	1.4 (3.0 lbs)
DCG-2B2-02T-20				
DCG-2B2-02G-10		3/8"	70 (18.49 gpm)	1.3 (1.3 lbs)
DCG-2B2-03G-10			120 (31.70 gpm)	3.1 (6.8 lbs)
<b>Fluid Type</b> 流體型式		ISO VG 32, 46, 68		
<b>Viscosity</b> 黏性 cSt		10~400 (59~1854 SSU)		
<b>Operating Temperature</b> 操作溫度 °C		-30~100 (-22~212°F)		
<b>Contamination Level</b> 污染標準		ISO4406. 21/19/16 NAS1638,10		
<b>Surface Treatment</b> 表面處理		Zinc Phosphate Compound 鋅 磷酸鹽 化合物		

● All screws with metric measure, if require inch measure, please contact us.

所附螺絲皆為公制標準規格品，若需英制螺絲請另外備註說明。

## ◆ HOW TO ORDER 編號說明

1	2	3	4	5	6	7					
DCG	—	2B2	—	02	G	—	Y	—	10	—	**

### 1 VALVE SERIES 系列名稱

DCG= Cam Operated Directional Valves  
凸輪行程換向閥

### 2 SPOOL TYPES 滑柱型式

Valve Type See Page 317  
閥型式見 317 頁面

### 3 SUBPLATE MOUNTING SIZE: 稱呼口徑

02=1/4"(6mm)	03=3/8"(9mm)
ISO CETOP3	ISO CETOP5
DIN NG 6	DIN NG 10
NFPA D03	NFPA D05

### 4 CONNECTING TYPE 連接型式

G:TYPE:BASEPLATE MOUNTING TYPE (板式連接)  
T:TYPE:THREADING TYPE (Only for 20 type)  
螺紋連接(只生產20型)

### 5 ROLLER POSITION 輪轉方向

See page 317 ~ 318  
見 317~318 頁面

### 6 DESIGN NO 設計編號

10:10 TYPE  
20:20 TYPE

### 7 MARK 標註

20 TYPE : NO Open 常開  
NC Close 常閉

※The Function only for 20 Type  
20 型方有此功能

# CAM OPERATED DIRECTIONAL VALVES

DCG SERIES

凸輪行程換向閥

## ◆ DIRECTION OF OIL FLOW FOR ROLLER POSITION: 凸輪位置與流量、方向說明

MODEL 型式	SYMBOL 記號	ROLLER POSITION VS .FLOW (mm) 凸輪位置與流量 (mm)
DCG-2B2-02G-20-NO		
DCG-2B2-02G-20-NC		
DCG-2B2-02G-10		
DCG-2B2-03G-10		

## ◆ PERFORMANCE 性能

Test Conditions 測試條件  
Oil Temperature 油溫度: 50°C (122°F)  
Viscosity 黏度: 35 cSt (163 SSU)

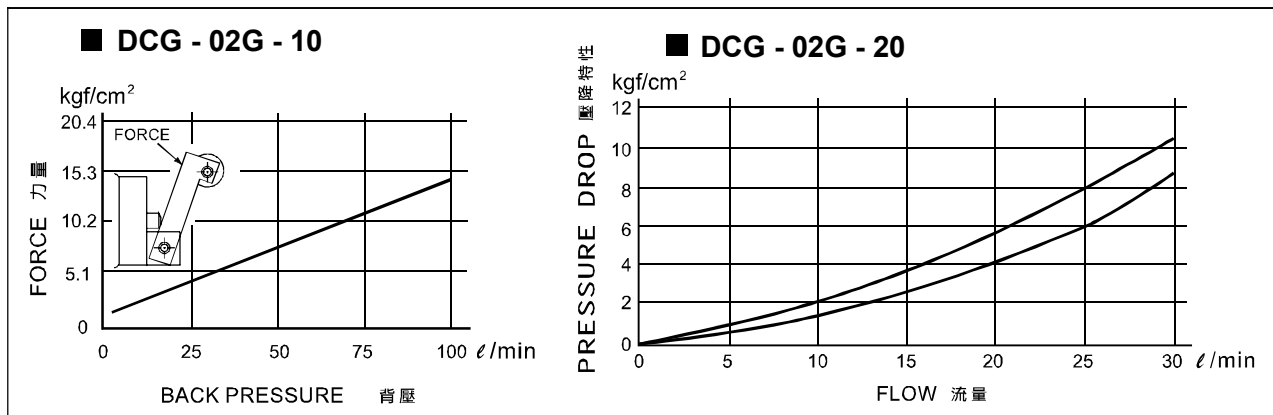

## ◆ DIMENSIONS 外型尺寸圖

DCG-\*\*\*-02G-10

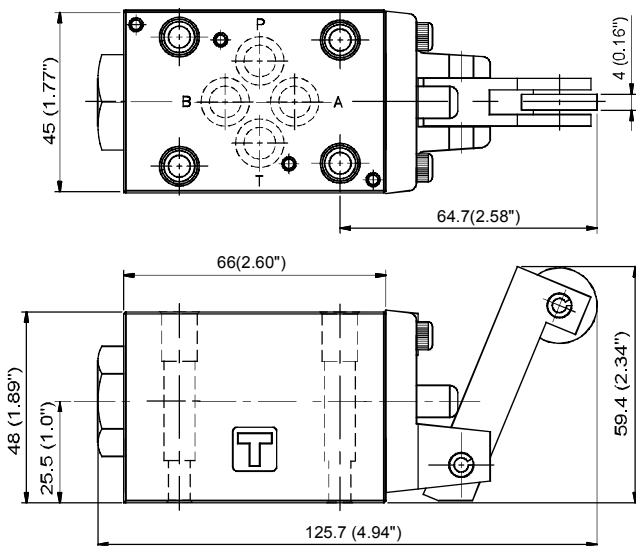

## ◆ Mounting Interface 基座尺寸圖

ISO 4401-AB-03-4-A

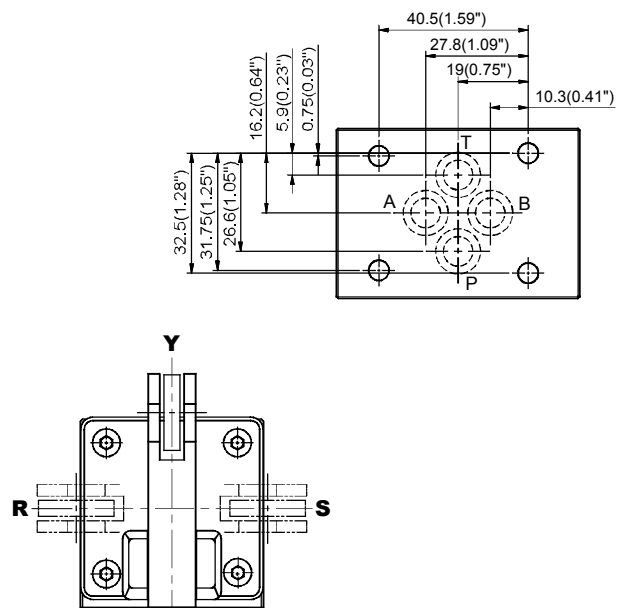

F  
DCG

# CAM OPERATED DIRECTIONAL VALVES

凸輪行程換向閥

DCG SERIES

## ◆ DIMENSIONS 外型尺寸圖

DCG-\*\*\*-02G-20

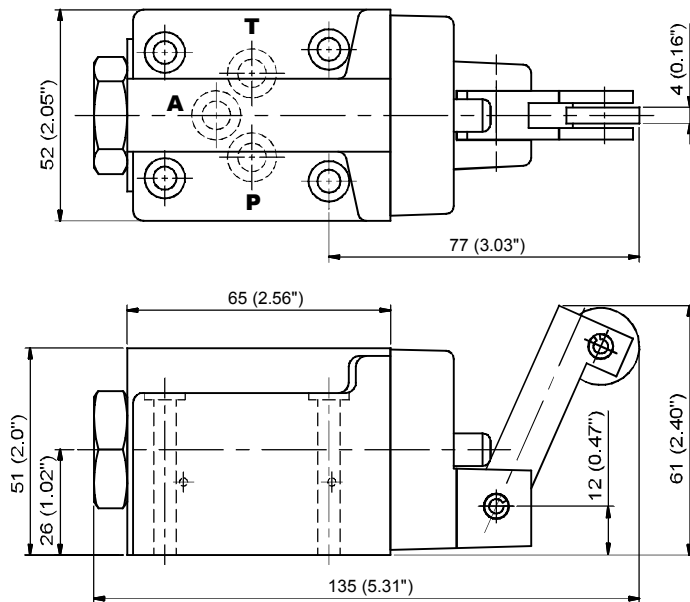

## ◆ Mounting Interface 基座尺寸圖

ISO 4401-AB-03-4-A

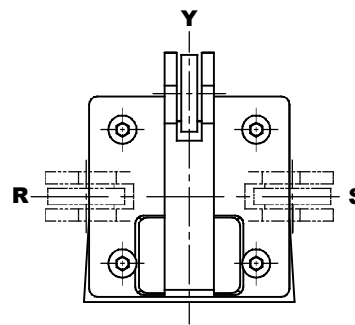
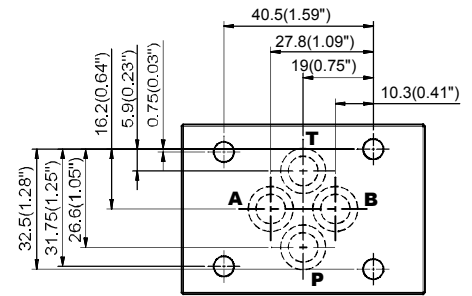

## ◆ DIMENSIONS 外型尺寸圖

DCG-\*\*\*-03G-10

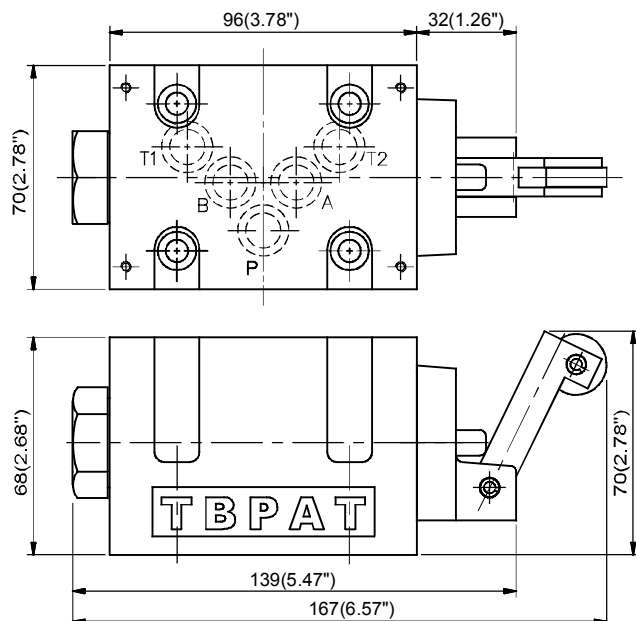

## ◆ Mounting Interface 基座尺寸圖

ISO 4401-AC-05-4-A

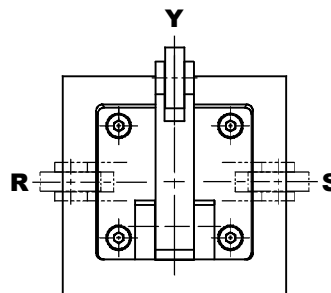
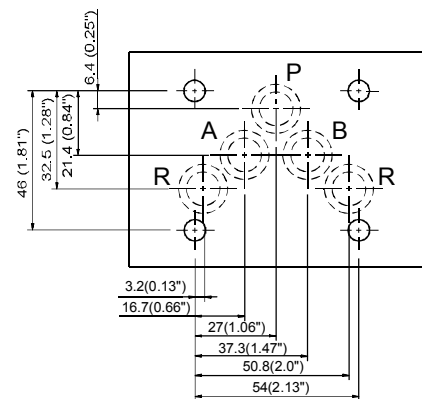

F  
DCG