

MODEL 型式

EDMS-04

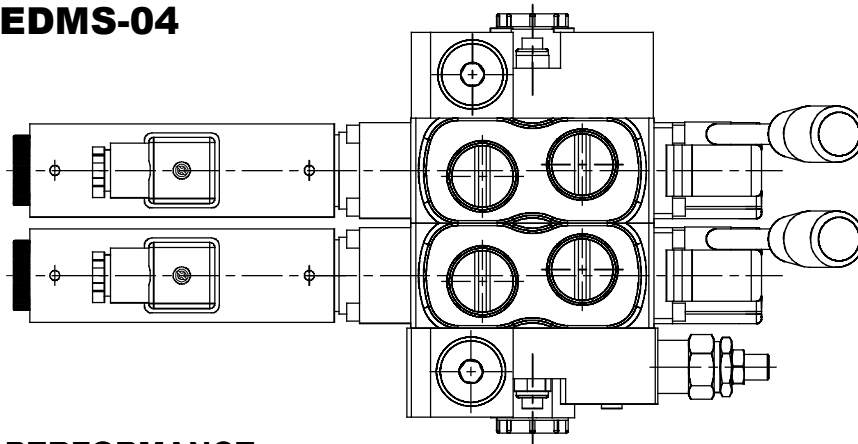

CONTROL PORT(S) 動作形式

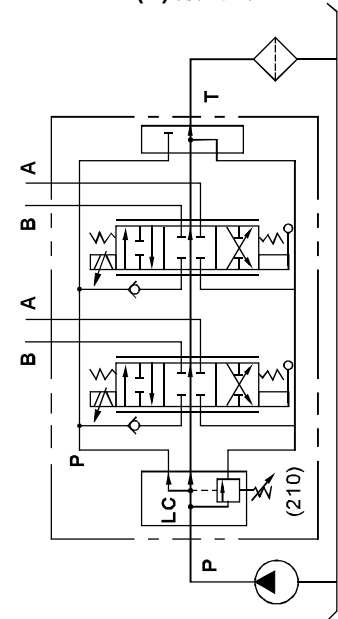

PERFORMANCE 特性曲線

See Page 064 見頁面064

SPECIFICATIONS 規格

Model Number 型式號碼	Maximum Pressure 最大壓力 bar	Maximum Current 最大電流 (A)		Maximum Flow 最大流量 lpm	Back Pressure-"T" 背壓-"T" bar	Weight 重量 Kg
		DC 12V	DC 24V			
EDMS-03-**-**	350 (5075 psi)	5	2.5	45 (11.9 gpm)	Max. 25 (362 psi) 不可大於 25	*
EDMS-04-**-**	350 (5075 psi)			70 (18.5 gpm)		
Fluid Type 流體型式				ISO VG 32, 46, 68		
Viscosity 黏性 cSt				10~400 (59~1854 SSU)		
Operating Temperature 操作溫度 °C				-30~100 (-22~212°F)		
Contamination Level 污染標準				ISO4406, 21/19/16 NAS1638,10		

● Standard pressure of relief valve sets at 210 bar.
出廠壓力調節閥標準設定最大壓力210bar

※Any request of setting pressure at 350 bar, please inform CW in advance.
※For relief valves, please refer to VRV-03 series.
※如需設定壓力為350bar需先告知 ※調壓閥請參考VRV-03系列

HOW TO ORDER 編號說明

1	2	3	4	5	6	7
EDMS	04	E2	1N	I*	U*	**

1 VALVE SERIES 系列名稱
EDMS = Proportional Solenoid Stack Valve
(Sectional)
比例電磁式多路換向閥(片式)

2 SUBPLATE MOUNTING SIZE 稱呼口徑
03 = G3/8" 04 = G1/2" 06 = G3/4"

3 SPOOL TYPES 滑柱型式
See Page 053
見頁面053

- E2= Proportional solenoid spool type is only applicable in E2.
比例電磁式手動多路閥滑柱型式只有E2.

4 NUMBER OF VALVE BLOCKS 連數
1N~7N = 1~7 Blocks

5 INLET SECTION 入油側
See Page 054
見頁面054

6 OUTLET SECTION 出油側
See Page 055
見頁面055

7 TYPE OF COIL 電磁線圈類型
D1: DC12V D2: DC24V

※If the products need to be assembled reversely, please advice CW in advance. The code of reverse is "L"
※產品需逆組裝請先告知佳王，逆組裝代號為"L"。

STACK VALVE

EDMS SERIES (PROPORTIONAL TYPE)

多路換向閥系列 (比例式)

◆ DIMENSIONS 外型尺寸圖

● CONNECTOR (on T1 Port)

轉接頭 (接口在T1)

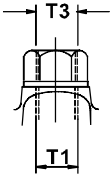

T1	T3	Purchasing No 訂貨編號
G 1/2"	G 1/2"	COG12
G 1/2"	G 1/2"	

※Optional Accessory
※特別附件

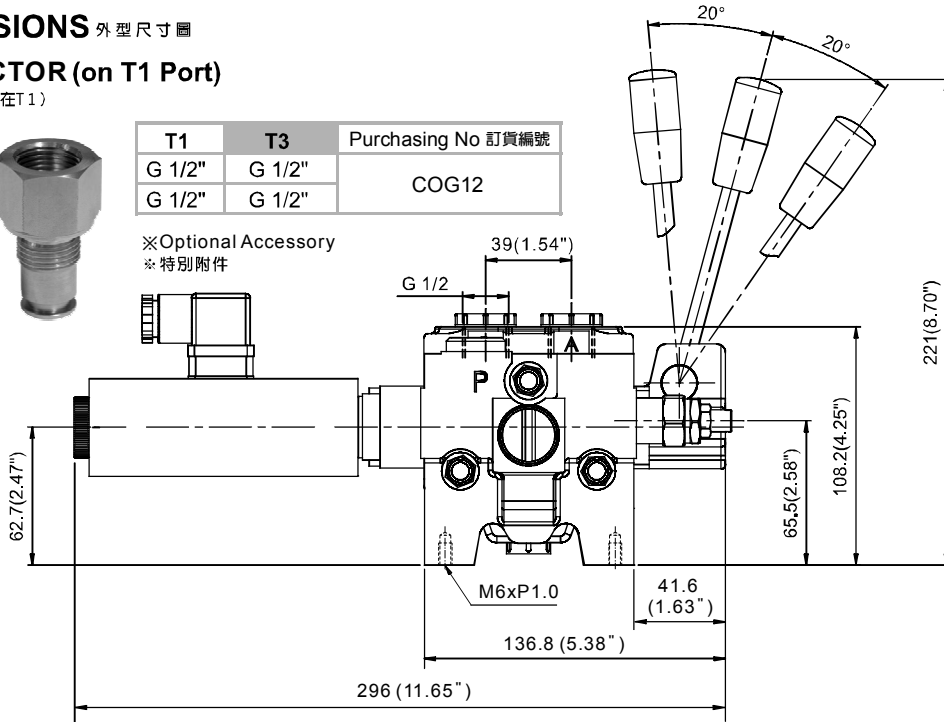

Carry-over

第二個連接系統之連接口

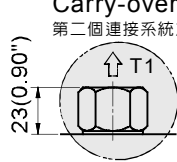

● CODE 編碼

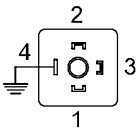

1-2 Port A
1-2 接口 A
1-3 Port B
1-3 接口 B

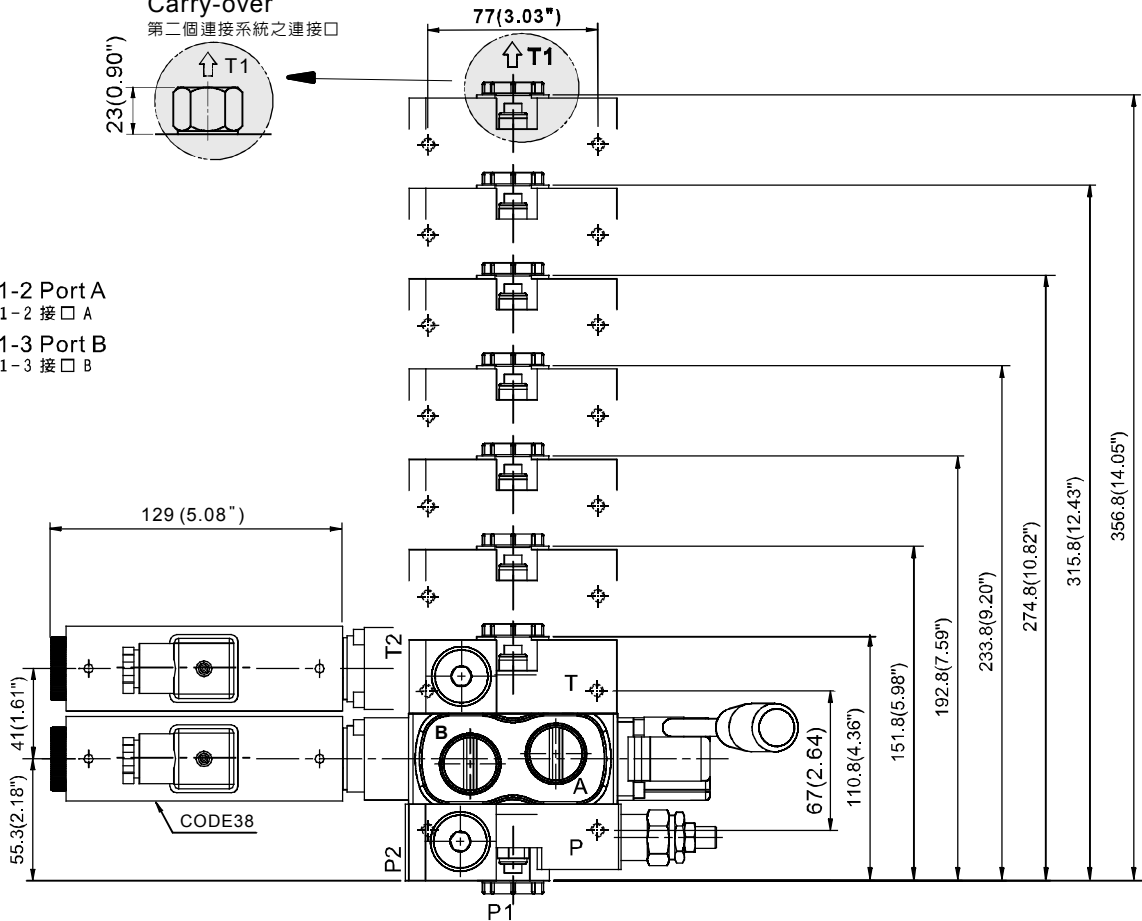

◆ AVAILABLE THREADS 通用螺紋

PORTS 閥口	P1	P2	A-B	T1	T2
EDMS-03-**-**	G 1/2"	G 1/2"	G 3/8"	G 1/2"	G 1/2"
EDMS-04-**-**	G 1/2"	G 1/2"	G 1/2"	G 1/2"	G 1/2"