

UNLOADING VALVES 卸載閥

SQ SERIES SQ 系列

◆ MODEL 型 式

SQ-01G

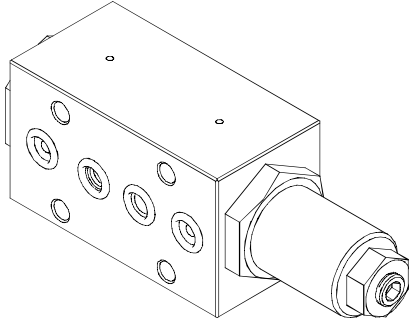

◆ CONTROL PORT(S) 動作形式

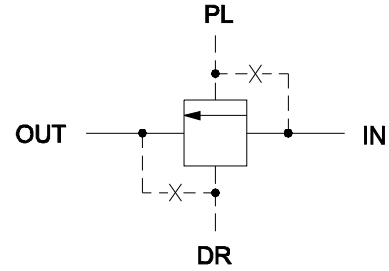

◆ SPECIFICATIONS 規 格

Model Number 型式號碼	Operating Pressure 操作壓力 bar	Flow 流量 lpm	Adjustment Pressure 壓力調整範圍 bar	Weight 重量 Kg
SQ-01G	250 (3625 psi)	35 (8.81 gpm)	L: 10~70 (bar) H: 50~140 (bar)	1.4(3.09 lps)
Fluid Type 流體型式		ISO VG 32, 46, 68		
Viscosity 黏性 cSt		10~400 (59~1854 SSU)		
Operating Temperature 操作溫度 °C		-15~70 (-5~158°F)		
Contamination Level 污染標準		$\beta_{10} \geq 75$, Under NAS Class 12, 25 μ		

◆ HOW TO ORDER 編號說明

1	2	3	4	5	6
SQ	—	01	G	—	* — * — *

1 VALVE SERIES 系列名稱

SQ= Unloading Valves 卸載閥

2 PORTING 閥口

1/4

3 CONNECTING TYPE 連接型式

G:TYPE:BASEPLATE MOUNTING TYPE (板式連接)

4 ADJUSTMENT PRESSURE 壓力調整範圍

L: 10~70 (bar)

H: 50~140 (bar)

5 POLIT OPERATED WAY 引導壓方式

INNER: PT OUTER: PE

內部: PT 外部: PE

6 RELEASE WAY 排洩方式

INNER: DI OUTER: DE

內部: DI 外部: DE

◆ DIMENSIONS 外型尺寸圖

外型尺寸圖

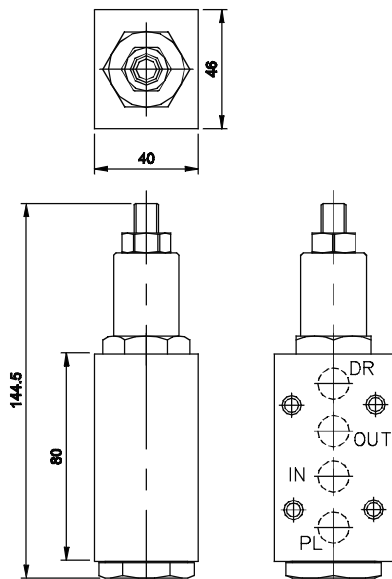

◆ Mounting Interface 基座尺寸圖

