

MODEL 型 式

VAS-02/03/04/06/08

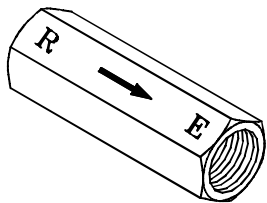

CONTROL PORT(S) 動作形式

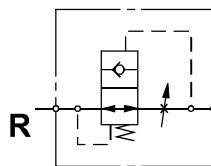

Hose burst check valve
防爆閥

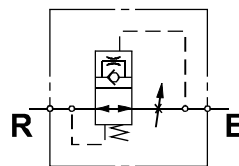

Hose burst valve
with orifice
帶節流口防爆閥

SPECIFICATIONS 規 格

Model Number 型式號碼	Maximum Pressure 最大壓力 bar	Maximum Flow 最大流量 lpm	Weight 重量 Kg
VAS-02	350 (5075 psi)	25 (6.6gpm)	0.12 (0.26 lbs)
VAS-03	350 (5075 psi)	50 (13.2gpm)	0.15 (0.33 lbs)
VAS-04	350 (5075 psi)	80 (21.1gpm)	0.23 (0.51 lbs)
VAS-06	350 (5075 psi)	150 (39.6gpm)	0.36 (0.79 lbs)
VAS-08	350 (5075 psi)	220 (58.1gpm)	1.05 (2.31 lbs)
Fluid Type 液體型式		ISO VG 32 , 46 , 68	
Viscosity 黏性 cSt		10~400 (59~1854 SSU)	
Operating Temperature 操作溫度 °C		-30~100 (-22~212°F)	
Contamination Level 污染標準		ISO4406. 21/19/16 NAS1638,10	

HOW TO ORDER 編號說明

1	2	3
VAS	— 03 —	— 00

1 VALVE SERIES 系列名稱

VAS = Hose Burst Protection Cartridge Type Valves
插入式防爆閥

2 SUBPLATE MOUNTING SIZE 稱呼口徑

02=G1/4" 03=G3/8" 04=G1/2" 06=G3/4" 08=G1"

3 ORIFICE DIMENSION 節流口尺寸

Code 編碼	Orifice Diameter 節流口直徑 (mm)	Code 編碼	Orifice Diameter 節流口直徑 (mm)
00	No orifice 無節流口	06	1
01	0.5	07	1.2
02	0.6	08	1.3
03	0.7	09	1.5
04	0.8	10	1.9
05	0.9	11	2

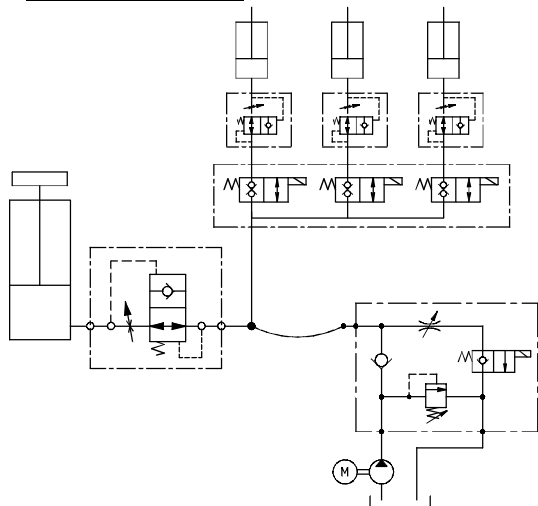

DESCRIPTION 說明

When the lowering speed exceeds preset value, as it might happen in case of hose failure, the flow is blocked. These valves should ideally be screwed directly into the actuator outlet port. Sealing parts are superfinished and enable to lock the load in the position where the actuator is in the moment of hose failure. These valves can be supplied, on request, allowing an emergency lowering of the load. It is recommended to fit a flow regulator valve downstream the hose burst valve, at the end of the flexible hose, to control the lowering speed at the nominal value. The "S" gap must be adjusted to allow a flow at least 50% over the nominal regulated flow from the actuator.

當降載速度超過預設值(軟管失效時可能發生這種情況), 流量會被切斷。這些閥應該直接擰入油壓缸出口端。在油壓缸發生軟管失效的位置, 密封零件是超精加工的, 能夠鎖定閥心的載荷, 可以按要​​求供應帶有節流口的閥, 這些閥允許緊急情況下降低負載。建議在防管道破裂閥的下游、軟管的末端安裝限速閥, 從而將降載速度控制為公稱值。必須調整 "S" 間隙, 以便允許通過油壓缸的流量至少超過調節流量的 50%。

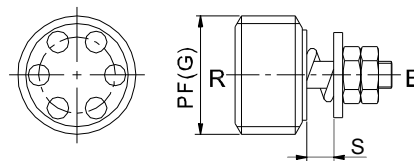

FITTING TOOL DIMENSION

安裝工具尺寸

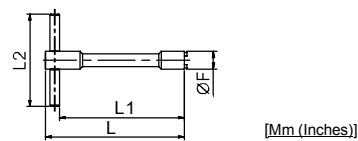

Type	F	L	L1	L2	Material number
G14	11.3(0.45")	120(4.72")	108(4.25")	80(3.15")	VAS-2005
G38	15(0.59")	120(4.72")	108(4.25")	80(3.15")	VAS-3005
G12	18.8(0.74")	120(4.72")	108(4.25")	80(3.15")	VAS-4005
G34	24(0.95")	120(4.72")	108(4.25")	80(3.15")	VAS-6005
G1	30(1.18")	120(4.72")	108(4.25")	80(3.15")	VAS-8005

◆ DIMENSIONS 外型尺寸圖

VAS-02

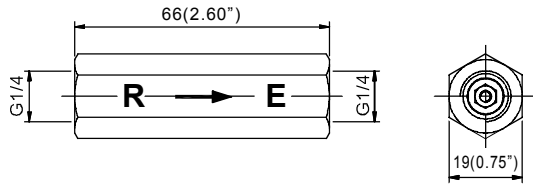

Pressure Drop 壓力降 R-E

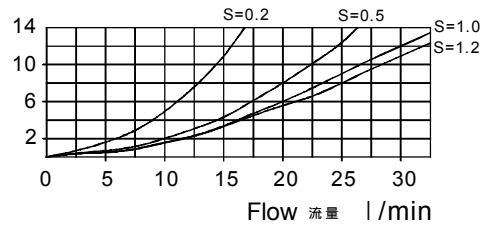

VAS-03

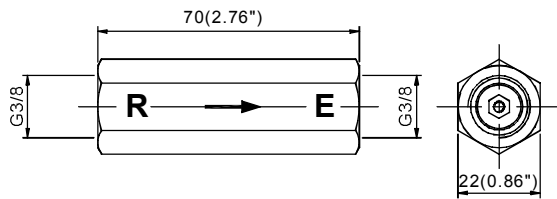

Pressure Drop 壓力降 R-E

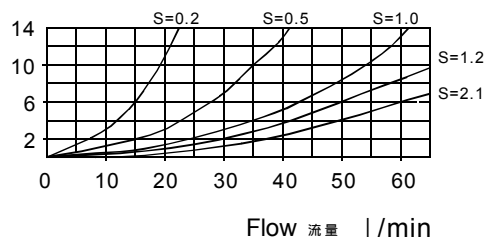

VAS-04

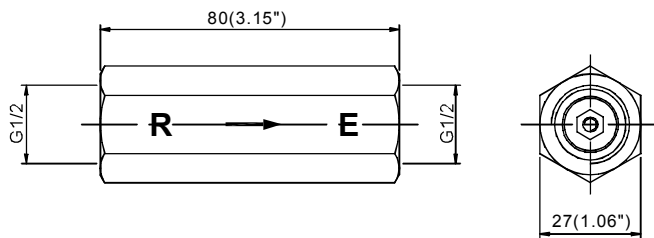

Pressure Drop 壓力降 R-E

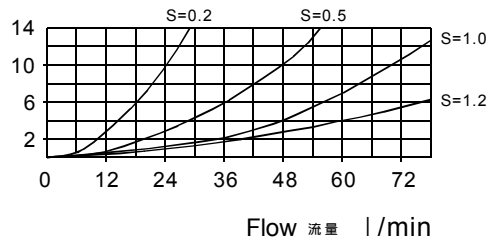

VAS-06

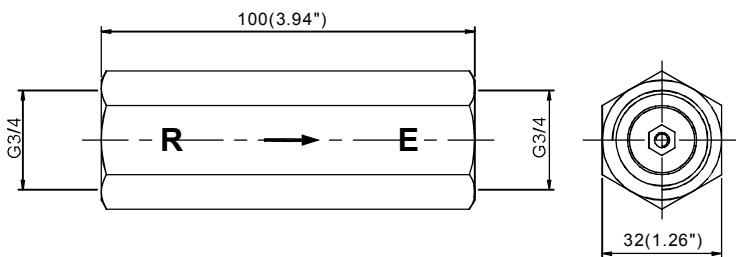

Pressure Drop 壓力降 R-E

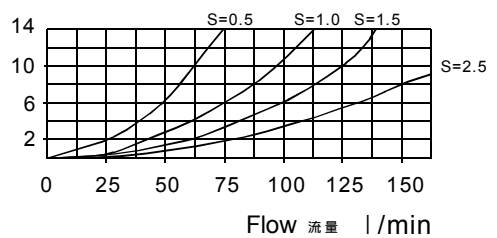

VAS-08

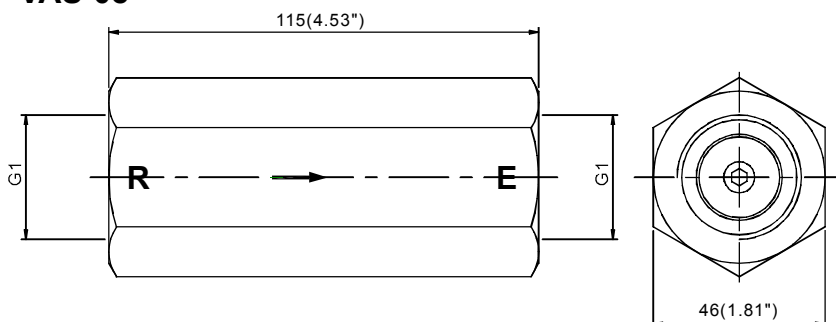

Pressure Drop 壓力降 R-E

