

COMPOUND VALVES 複合閥

VCBV SERIES COMPOUND VALVES VCBV系列複合閥

◆ MODEL 型式

VCBV-08

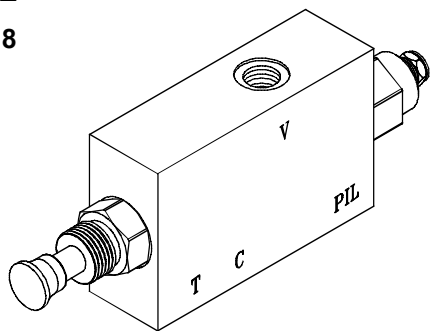

◆ CONTROL PORT(S) 動作形式

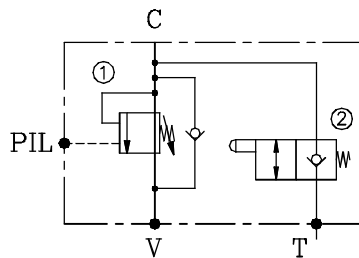

◆ SPECIFICATIONS 規格

Model Number 型式號碼	Maximum Pressure 最大壓力 bar	Pilot Ratio 引導比例	Adjustment Pressure 壓力調整範圍 bar	Maximum Flow 最大流量 lpm	Weight 重量 Kg
VCBV-08	345(5000 psi)	3:1 / 10:1	* ~345	30 (7.93gpm)	2.5 (5.51 lbs)
Fluid Type 流體型式			ISO VG 32, 46, 68		
Viscosity 黏性 cSt			10~400 (59~1854 SSU)		
Operating Temperature 操作溫度 °C			-15~70 (-5~158°F)		
Contamination Level 污染標準			$\beta_{10} \geq 75$, Under NAS Class 12, 25 μ		

◆ HOW TO ORDER 編號說明

1	2	3	4
VCBV	— 08 —	— 35 —	— 3A

1 VALVE SERIES 系列名稱

VCBV=COMPOUND VALVES
複合閥

3 ADJUSTMENT PRESSURE 壓力調整範圍

10 : 30 ~ 105 (bar) 17 : 70 ~ 175 (bar)
28 : 70 ~ 280 (bar) 35 : 145 ~ 345 (bar)

2 SUBPLATE MOUNTING SIZE 稱呼口徑

Size : 08

4 PILOT RATIO 引導比例

3A : 3:1
10A : 10:1

◆ DIMENSIONS 外型尺寸圖

外型尺寸圖

