

PRESSURE CONTROL VALVES 壓力控制閥

VDS SERIES CARTRIDGE PILOT OPERATED VALVES VDS 系列插入式引導式方向閥

◆ MODEL 型式

VDS-10

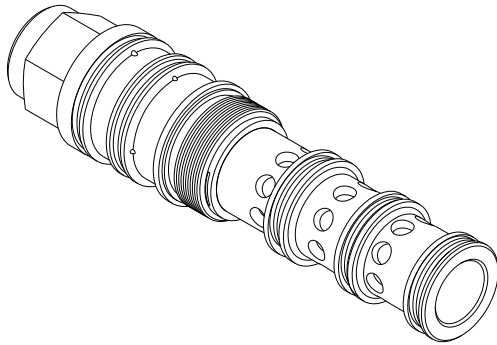

◆ PERFORMANCE 特性曲線

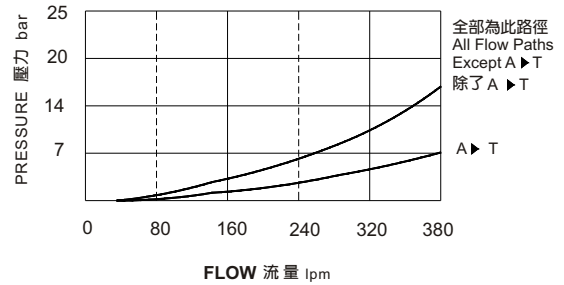

◆ SPECIFICATIONS 規格

Model Number 型式號碼	Operating Pressure 操作壓力 bar	Flow 流量 lpm	Weight 重量 Kg
VDS-10	350 (5076 psi)	320 (84.54 gpm)	2 (4.4 lbs)
Fluid Type 流體型式		ISO VG 32, 46, 68	
Viscosity 黏性 cSt		10~400 (59~1854 SSU)	
Operating Temperature 操作溫度 °C		-15~70 (-5~158 °F)	
Contamination Level 污染標準		ISO4406. 21/19/16 NAS1638,10	

◆ HOW TO ORDER 編號說明

1	2	3
VDS	10	C2

- 1 VALVE SERIES 系列名稱**
VDS = CARTRIDGE PILOT OPERATED VALVE
插入式引導式方向閥

- 2 SUBPLATE MOUNTING SIZE 稱呼口徑**
Size : T-64A
Cavity 孔口: CST-64A
See Cavities Dimensions Page
見孔口尺寸頁面

- 3 SPOOL CONFIGURATION CAPACITY (Lpm)**
軸型式流量

	10
C2	756
C6	378
C3	378
C4	756
C10	567
C12	567

Typical switching pilot pressure differential between pilot ports 5 and 6 is 13.79 bar.
做切換時油口5和6的壓力差為13.79bar

◆ CONTROL PORT(S) 動作形式

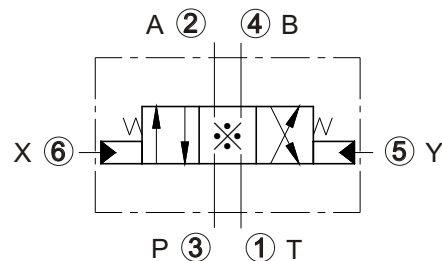

◆ DIMENSIONS 外型尺寸圖

