

◆ **MODEL** 型 式

DBK-20

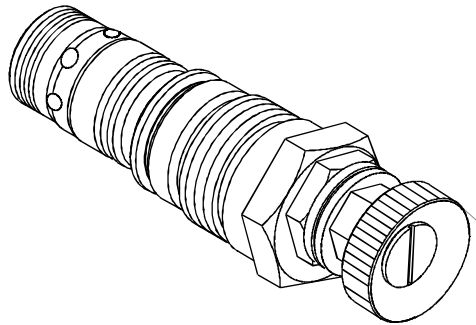

◆ **CONTROL PORT(S)** 動作形式

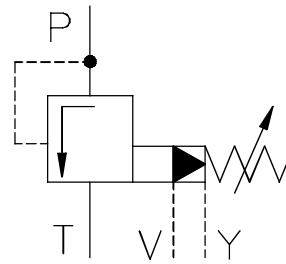

◆ **SPECIFICATIONS** 規 格

Model Number 型式號碼	Maximum Pressure 最大壓力 bar	Maximum Flow 最大流量 lpm	Weight 重量 Kg
DBK-20	350 (5076 psi)	300 (79.25 gpm)	0.4 (0.88 lbs)
<b>Fluid Type</b> 流體型式		ISO VG 32, 46, 68	
<b>Viscosity</b> 黏性 cSt		10~400 (59~1854 SSU)	
<b>Operating Temperature</b> 操作溫度 °C		-30~100 (-22~212°F)	
<b>Contamination Level</b> 污染標準		ISO4406. 20/18/15 NAS1638. 9	

◆ **HOW TO ORDER** 編號說明

<b>1</b>	<b>2</b>	<b>3</b>	<b>4</b>
DBK	20	*	*

※ This product in normal situation is to drain the oil outside.  
本產品正常狀況都為外部洩油

**1 VALVE SERIES** 系列名稱

DBK= Cartridge Type Relief Valves  
插入式調壓閥

**2 PORTING** 閥口

06=3/4"(19mm)  
ISO CETOP8  
DIN NG 25  
NFPA D08

**3 ADJUSTMENT PRESSURE** 壓力調整範圍

Code 編碼	Adjustment pressure 壓力調整範圍
1	※ ~ 100 (bar)
3	20 ~ 350 (bar)

**4 PILOT WAY** 引導方式

V: OUTER V:外部引導 (VE)  
NONE: STANDARD 無:標準型 (內部 VE)

◆ **DIMENSIONS** 外型尺寸圖

