

PRESSURE CONTROL VALVES 壓力控制閥

VBCL SERIES SINGLE DIRECTION COUNTER BALANCE VALVES VBCL 系列單向抗衡閥

◆ MODEL 型 式

VBCL-T120

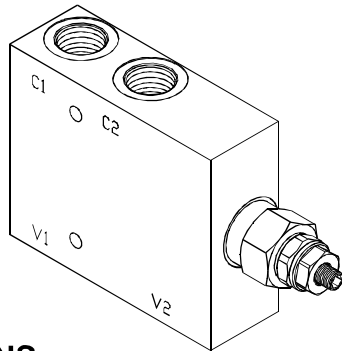

◆ PERFORMANCE (Cartridge Only)

特性曲線

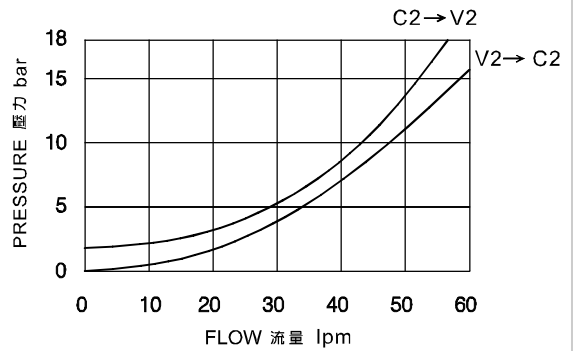

◆ SPECIFICATIONS 規 格

Model Number 型式號碼	Maximum Pressure 最大壓力 bar	Pilot Ratio 引導比例	Adjustment Pressure 壓力調整範圍 bar	Maximum Flow 最大流量 Lpm	Weight 重量 Kg
VBCL-T120	350 (5076 psi)	8:1 / 3:1	* ~ 350	60 (15.85 gpm)	3.6 (7.94 lbs)
Fluid Type 流體型式			ISO VG 32,46,68		
Viscosity 黏性 cSt			10~400 (59~1854SSU)		
Operating Temperature 操作溫度 °C			-15~70 (-5~158°F)		
Contamination Level 污染標準			ISO4406. 21/19/16 NAS1638,10		

◆ HOW TO ORDER 編號說明

1	2	3	4
VBCL	T120	— 35 —	3A

1 VALVE SERIES 系列名稱

VBCL=SINGLE DIRECTION COUNTER BALANCE VALVES

單向抗衡閥

2 SUBPLATE MOUNTING SIZE 稱呼口徑

Size:T120=G1/2"

3 ADJUSTMENT PRESSURE 壓力調整範圍

Order 編號	Adjustment pressure 壓力調整範圍	Pilot ratio 引導比例
20	70 ~ 210 (bar)	3:1
35	140 ~ 350 (bar)	8:1

◆ CONTROL PORT(S) 動作形式

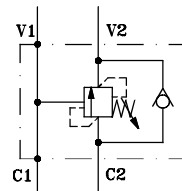

4 PILOT RATIO 引導比例

3A: 3:1

8A: 8:1

◆ DIMENSIONS 外型尺寸圖

