

PRESSURE CONTROL VALVES 壓力控制閥

VBSO SERIES CARTRIDGE TYPE COUNTER BALANCE VALVES VBSO 系列插入式抗衡閥

◆ MODEL 型式

VBSO-03T

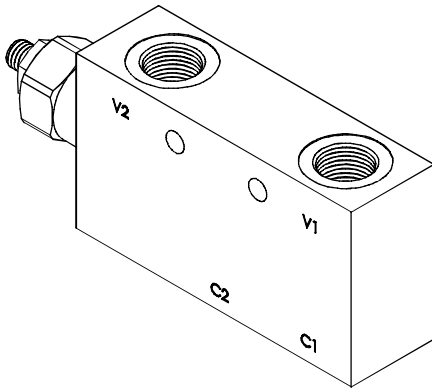

◆ PERFORMANCE (Cartridge Only)

特性曲線

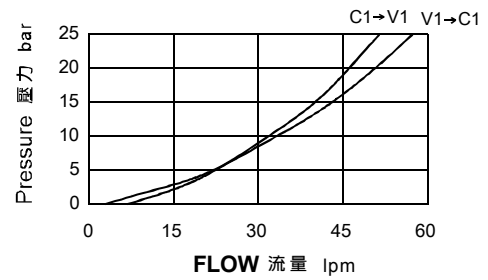

◆ SPECIFICATIONS 規格

Model Number 型式號碼	Maximum Pressure 最大壓力 bar	Pilot Ratio 引導比例	Adjustment Pressure 壓力調整範圍 bar	Maximum Flow 最大流量 Lpm	Weight 重量 Kg
VBSO-03T	350 (5076 psi)	4.3 : 1	100~350	45 (11.89 gpm)	1.38 (3.04 lbs)
Fluid Type 流體型式			ISO VG 32,46,68		
Viscosity 黏性 cSt			10~400 (59~1854SSU)		
Operating Temperature 操作溫度 °C			-15~70 (-5~158°F)		
Contamination Level 污染標準			ISO4406. 21/19/16 NAS1638,10		

◆ HOW TO ORDER 編號說明

1	2	3
VBSO	03T	*

◆ CONTROL PORT(S) 動作形式

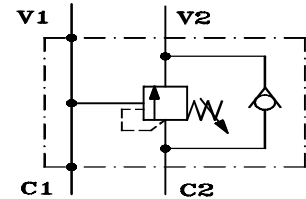

1 VALVE SERIES 系列名稱

VBSO=COUNTER BALANCE VALVES
抗衡閥

2 SUBPLATE MOUNTING SIZE 稱呼口徑

03= 3/8"

3 ADJUSTMENT PRESSURE 壓力調整範圍

Order 編號	Adjustment pressure 壓力調整範圍
3	100 ~ 350 (bar)

◆ DIMENSIONS 外型尺寸圖

