

◆ **MODEL 型 式**
VCB-10

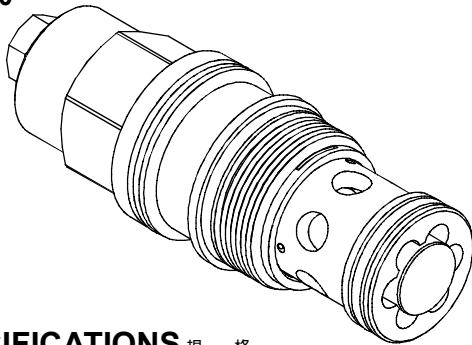

◆ **PERFORMANCE (Cartridge Only)**

特性曲線

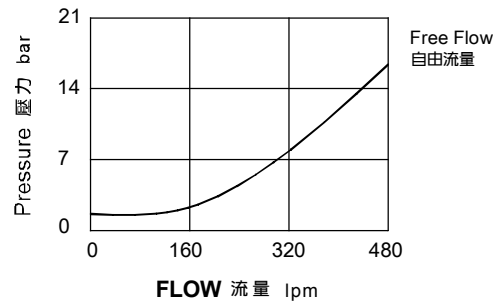

◆ **SPECIFICATIONS 規 格**

Model Number 型式號碼	Maximum Pressure 最大壓力 bar	Pilot Raion 引導比例	Adjustment Pressure 壓力調整範圍 Bar	Maximum Flow 最大流量 lpm	Weight 重量 Kg
VCB-10	350 (5076 psi)	1.5:1 / 2.3:1 / 3:1 / 4.5:1 / 10:1	* ~ 350	480 (105.58 gpm)	1.6 (3.53 lbs)
Fluid Type 流體型式			ISO VG 32, 46, 68		
Viscosity 黏性 cSt			10~400 (59~1854 SSU)		
Operating Temperature 操作溫度 °C			-15~70 (-5~158 °F)		
Contamination Level 污染標準			ISO4406. 21/19/16 NAS1638,10		

◆ **HOW TO ORDER 編號說明**

1	2	3	4	5
VCB	10	— 10	— 3A	— *

1 VALVE SERIES 系列名稱

VCB =OVERCENTRE VALVE PILOT ASSISTED
RELIEF WITH CHECK
引導式抗衝洩載閥

2 SUBPLATE MOUNTING SIZE 稱呼口徑

10 :T-19A
Cavity 孔口:CST-19A
See Page Appendixes-A_007
見附錄 A_007 頁面

3 ADJUSTMENT PRESSURE 壓力調整範圍

Check Spring Pressure 1.8bar 止逆閥彈簧壓力 1.8bar			Check Spring Pressure 0.3bar 止逆閥彈簧壓力 0.3bar		
Order 編號	Adjustment pressure 壓力調整範圍	Pilot ratio 引導比例	Order 編號	Adjustment pressure 壓力調整範圍	Pilot ratio 引導比例
10	25 ~ 105 (bar)	1.5:1	25	25 ~ 105 (bar)	1.5:1
28	70 ~ 280 (bar)	3:1	70	70 ~ 280 (bar)	3:1
17	70 ~ 175 (bar)	2.3:1	80	70 ~ 175 (bar)	2.3:1
35	140 ~ 350 (bar)	4.5:1 10:1	14	140 ~ 350 (bar)	4.5:1 10:1

4 PILOT RATIO 引導比例

1.5A : 1.5:1 (With sealed pilot) 導壓室密封
2.3A : 2.3:1 (With sealed pilot) 導壓室密封
3A : 3:1 (With sealed pilot) 導壓室密封
4A : 4.5:1 (With sealed pilot) 導壓室密封
10A : 10:1 (With sealed pilot) 導壓室密封

5 ADJUSTMENT OPTION 調整選擇

NONE	NONE:TOOL ADJUST 無：工具調整式	
C	C:TAMPER RESISTANT COVER C：防濫封蓋	

◆ **CONTROL PORT(S) 動作形式**

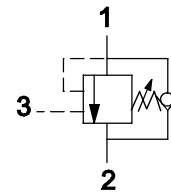

◆ **DIMENSIONS 外型尺寸圖**

