

PRESSURE CONTROL VALVES 壓力控制閥

VCBA SERIES CARTRIDGE TYPE COUNTER BALANCE VALVES (RESTRICTIVE) VCBA 系列插入式抗衝閥(全限流型)

MODEL 型式 VCBA-02

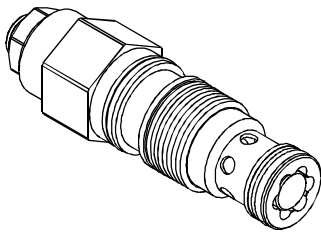

DESCRIPTION 說明

Counterbalance valves with pilot assist are meant to control an overrunning load. The check valve allows free flow from the directional valve (port 2) to the load (port 1) While a direct-acting, pilot-assisted relief valve controls flow from port 1 to port 2. Pilot assist at port 3 lowers the effective setting of the relief valve at a rate determined by the pilot ratio. Other names for this valve include motion control valve and over center valve. 帶先導協助開啟的平衡閥是用來控制超馳負載。它允許油液從方向閥(口2)到負載口(口1)單向自由流通,同時直動式,先導協助溢流閥功能可以控制從口1到口2液的溢流。口3的先導協助以先導比率的作用系數降低了溢流功能的有效設定值。此閥還被稱為運動控制閥或者越過中心閥。

PERFORMANCE(Cartridge Only) 特性曲線

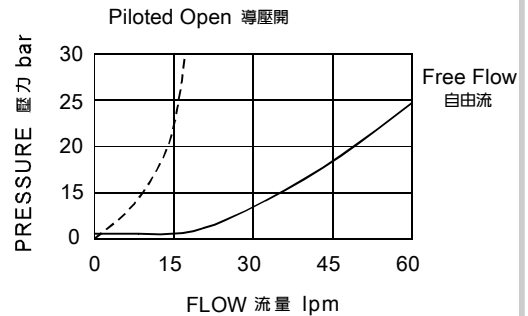

SPECIFICATIONS 規格

Model Number 型式號碼	Maximum Pressure 最大壓力 bar	Pilot Ratio 引導比例	Adjustment Pressure 壓力調整範圍 bar	Maximum Flow 最大流量 lpm	Weight 重量 Kg
VCBA-02	350 (5076 psi)	1.5:1 / 2:1 / 2.3:1 / 3:1 / 4.5:1 / 10:1	* ~ 350	20 (5.28 gpm)	0.2 (0.44 lbs)
Fluid Type 流體型式			ISO VG 32, 46, 68		
Viscosity 黏性 cSt			10~400 (59~1854 SSU)		
Operating Temperature 操作溫度 °C			-30~100 (-22~212°F)		
Contamination Level 污染標準			ISO4406. 21/19/16 NAS1638,10		

HOW TO ORDER 編號說明

1	2	3	4	5
VCBA	02	—	10	—
			3A	—
				*

1 VALVE SERIES 系列名稱

VCBA = Overcentre Valve Pilot Assisted Relief With Check (Restrictive) 引導式抗衝洩載閥 (全限流型)

2 PORTING 閥口

02:T-11A See Page Appendixes-A_006
Cavity 孔口: CST-11A 見附錄A_006 頁面

3 ADJUSTMENT PRESSURE 壓力調整範圍

Check Spring Pressure 1.8bar 止逆閥彈簧壓力 1.8bar			Check Spring Pressure 0.3bar 止逆閥彈簧壓力 0.3bar		
Order 編號	Adjustment pressure 壓力調整範圍	Pilot ratio 引導比例	Order 編號	Adjustment pressure 壓力調整範圍	Pilot ratio 引導比例
06	* ~ 60 (bar)	3:1	25	25 ~ 105 (bar)	1.5:1
10	25 ~ 105 (bar)	1.5:1	70	70 ~ 280 (bar)	2:1
28	70 ~ 280 (bar)	2:1	80	70 ~ 175 (bar)	3:1
17	70 ~ 175 (bar)	3:1			2.3:1
35	140 ~ 350 (bar)	4.5:1	14	140 ~ 350 (bar)	10:1

4 PILOT RATIO 引導比例

- 1.5A : 1.5:1 (With sealed pilot) 導壓室密封
- 2A : 2:1 (With bleed through pilot) 透流導壓
- 2.3A : 2.3:1 (With sealed pilot) 導壓室密封
- 3A : 3:1 (With sealed pilot) 導壓室密封
- 4A : 4.5:1 (With sealed pilot) 導壓室密封
- 10A : 10:1 (With sealed pilot) 導壓室密封

5 ADJUSTMENT OPTION 調整選擇

NONE	NONE:TOOL ADJUST 無:工具調整式	
C	C:TAMPER RESISTANT COVER C:防調封蓋	

TECHNICAL FEATURES 技術特性

- Counterbalance valves should be set at least 1.3 time the maximum load induced pressure. 平衡閥的設定值應該至少為負載壓力值的1.3倍。
- Restrictive valves have no relief capacity other than as a thermal relief. 全限流閥泄壓量不足,但是具備熱泄功能。
- Reseat exceeds 85% of set pressure when the valve is standard set. Settings lower than the standard est pressure may result in lower reseal percentages. 標準設定下,閥的復位壓力值高於開啟值的85%。當設定值小於標準設定值,復位壓力值的百分比將相對變小。
- This valve has positive seals between all ports. 這種閥在所有的口之間都完全密封。

DIMENSIONS 外型尺寸圖

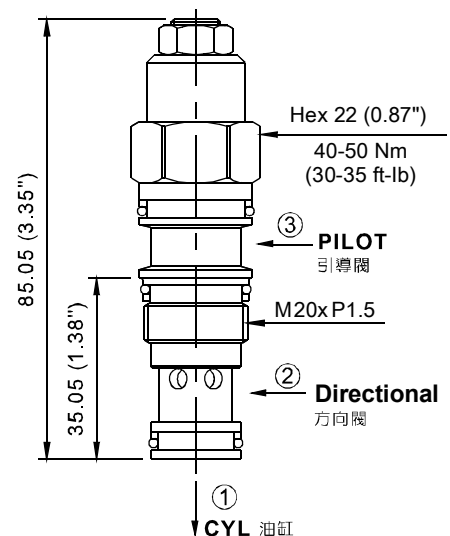

CONTROL PORT(S) 動作形式

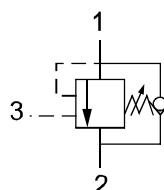

◆ **MODEL 型 式**
VCBA-03

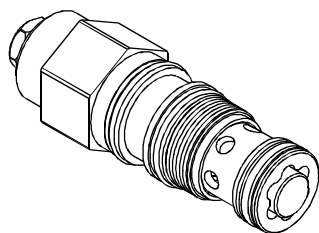

◆ **DESCRIPTION 說明**

Counterbalance valves with pilot assist are meant to control an overrunning load. The check valve allows free flow from the directional valve (port 2) to the load (port 1) While a direct-acting, pilot-assisted relief valve controls flow from port 1 to port 2. Pilot assist at port 3 lowers the effective setting of the relief valve at a rate determined by the pilot ratio. Other names for this valve include motion control valve and over center valve. 帶先導協助開啟的平衡閥是用來控制超馳負載。它允許油液從方向閥(口2)到負載口(口1)單向自由流通,同時直動式,先導協助溢流閥功能可以控制從口1到口2液的溢流。口3的先導協助以先導比率的作用系數降低了溢流功能的有效設定值。此閥還被稱為運動控制閥或者越過中心閥。

◆ **PERFORMANCE(Cartridge Only) 特性曲線**

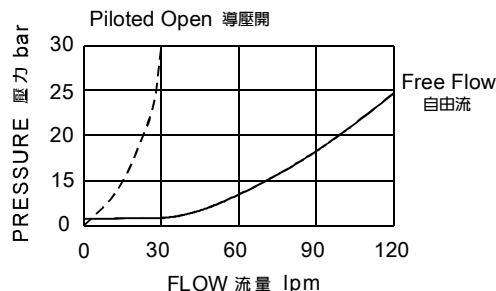

◆ **SPECIFICATIONS 規格**

Model Number 型式號碼	Maximum Pressure 最大壓力 bar	Pilot Ratio 引導比例	Adjustment Pressure 壓力調整範圍 bar	Maximum Flow 最大流量 lpm	Weight 重量 Kg
VCBA-03	350 (5076 psi)	1.5:1 / 2:1 / 2.3:1 / 3:1 / 4.5:1 / 10:1	* ~ 350	30 (7.93 gpm)	0.3 (0.68 lbs)
Fluid Type 流體型式			ISO VG 32 , 46 , 68		
Viscosity 黏性 cSt			10~400 (59~1854 SSU)		
Operating Temperature 操作溫度 °C			-30~100 (-22~212°F)		
Contamination Level 污染標準			ISO4406. 21/19/16 NAS1638,10		

◆ **HOW TO ORDER 編號說明**

1	2	3	4	5
VCBA	03	— 10 —	3A	*

1 VALVE SERIES 系列名稱

VCBA = Overcentre Valve Pilot Assisted Relief With Check (Restrictive) 引導式抗衝洩載閥 (全限流型)

2 PORTING 閥口

03:T-2A
Cavity 孔口:CST-2A

See Page Appendixes-A_006
見附錄A_006 頁面

3 ADJUSTMENT PRESSURE 壓力調整範圍

Check Spring Pressure 1.8bar 止逆閥彈簧壓力 1.8bar		
Order 編號	Adjustment pressure 壓力調整範圍	Pilot ratio 引導比例
06	* ~ 60 (bar)	3:1
10	25 ~ 105 (bar)	1.5:1
28	70 ~ 280 (bar)	2:1
17	70 ~ 175 (bar)	3:1
35	140 ~ 350 (bar)	2.3:1
		4.5:1
		10:1

Check Spring Pressure 0.3bar 止逆閥彈簧壓力 0.3bar		
Order 編號	Adjustment pressure 壓力調整範圍	Pilot ratio 引導比例
25	25 ~ 105 (bar)	1.5:1
70	70 ~ 280 (bar)	2:1
80	70 ~ 175 (bar)	3:1
14	140 ~ 350 (bar)	2.3:1
		4.5:1
		10:1

4 PILOT RATIO 引導比例

- 1.5A : 1.5:1 (With sealed pilot) 導壓室密封
- 2A : 2:1 (With bleed through pilot) 透流導壓
- 2.3A : 2.3:1 (With sealed pilot) 導壓室密封
- 3A : 3:1 (With sealed pilot) 導壓室密封
- 4A : 4.5:1 (With sealed pilot) 導壓室密封
- 10A : 10:1 (With sealed pilot) 導壓室密封

5 ADJUSTMENT OPTION 調整選擇

NONE	NONE:TOOL ADJUST 無:工具調整式	
C	C:TAMPER RESISTANT COVER C:防調封蓋	

◆ **TECHNICAL FEATURES 技術特性**

- Counterbalance valves should be set at least 1.3 time the maximum load induced pressure. 平衡閥的設定值應該至少為負載壓力值的1.3倍。
- Restrictive valves have no relief capacity other than as a thermal relief. 全限流閥泄壓量不足,但是具備熱泄功能。
- Reseat exceeds 85% of set pressure when the valve is standard set. Settings lower than the standard est pressure may result in lower reseal percentages. 標準設定下,閥的復位壓力值高於開啟值的85%。當設定值小於標準設定值,復位壓力值的百分比將相對變小。
- This valve has positive seals between al ports. 這種閥在所有的口之間都完全密封。

◆ **DIMENSIONS 外型尺寸圖**

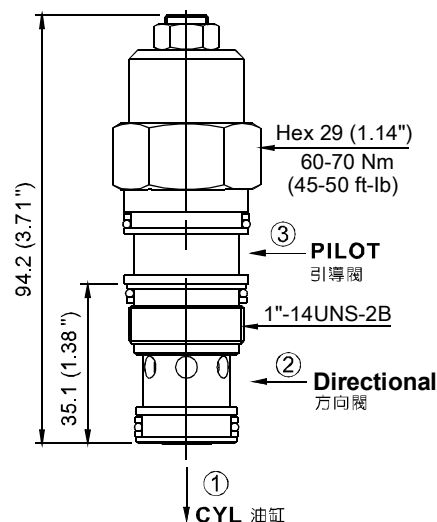

◆ **CONTROL PORT(S) 動作形式**

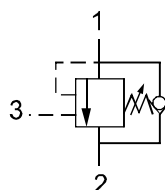

◆ MODEL 型式 VCBA-06

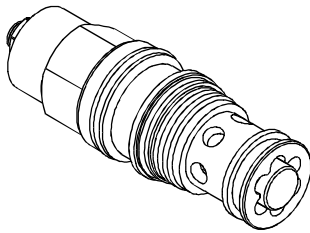

◆ DESCRIPTION 說明

Counterbalance valves with pilot assist are meant to control an overrunning load. The check valve allows free flow from the directional valve (port 2) to the load (port 1). While a direct-acting, pilot-assisted relief valve controls flow from port 1 to port 2. Pilot assist at port 3 lowers the effective setting of the relief valve at a rate determined by the pilot ratio. Other names for this valve include motion control valve and over center valve. 帶先導協助開啟的平衡閥是用來控制超馳負載。它允許油液從方向閥(口2)到負載口(口1)單向自由流通,同時直動式,先導協助溢流閥功能可以控制從口1到口2液的溢流。口3的先導協助以先導比率的作用系數降低了溢流功能的有效設定值。此閥還被稱為運動控制閥或者越過中心閥。

◆ PERFORMANCE(Cartridge Only) 特性曲線

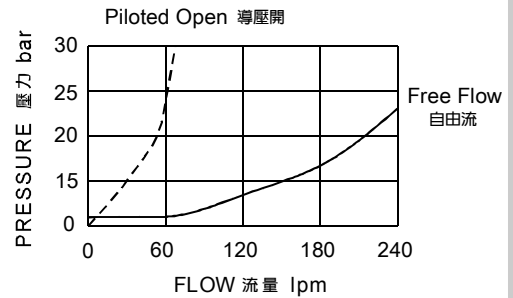

◆ SPECIFICATIONS 規格

Model Number 型式號碼	Maximum Pressure 最大壓力 bar	Pilot Ratio 引導比例	Adjustment Pressure 壓力調整範圍 bar	Maximum Flow 最大流量 lpm	Weight 重量 Kg
VCBA-06	350 (5076 psi)	1.5:1 / 2.3:1 / 3:1 / 4.5:1 / 10:1	* ~ 350	60 (15.85 gpm)	0.61 (1.35 lbs)
Fluid Type 流體型式			ISO VG 32, 46, 68		
Viscosity 黏性 cSt			10~400 (59~1854 SSU)		
Operating Temperature 操作溫度 °C			-30~100 (-22~212°F)		
Contamination Level 污染標準			ISO4406. 21/19/16 NAS1638,10		

◆ HOW TO ORDER 編號說明

1	2	3	4	5
VCBA	06	—	10	—
			3A	—
				*

1 VALVE SERIES 系列名稱

VCBA = Overcentre Valve Pilot Assisted Relief With Check (Restrictive) 引導式抗衡洩載閥 (全限流型)

2 PORTING 閥口

06:T-17A

Cavity 孔口: CST-17A

See Page Appendixes-A_007

見附錄A_007 頁面

3 ADJUSTMENT PRESSURE 壓力調整範圍

Check Spring Pressure 1.8bar 止逆閥彈簧壓力 1.8bar			Check Spring Pressure 0.3bar 止逆閥彈簧壓力 0.3bar		
Order 編號	Adjustment pressure 壓力調整範圍	Pilot ratio 引導比例	Order 編號	Adjustment pressure 壓力調整範圍	Pilot ratio 引導比例
10	25 ~ 105 (bar)	1.5:1	25	25 ~ 105 (bar)	1.5:1
28	70 ~ 280 (bar)	3:1	70	70 ~ 280 (bar)	3:1
17	70 ~ 175 (bar)	2.3:1	80	70 ~ 175 (bar)	2.3:1
35	140 ~ 350 (bar)	4.5:1	14	140 ~ 350 (bar)	10:1

4 PILOT RATIO 引導比例

1.5A : 1.5:1 (With sealed pilot) 導壓室密封

2.3A : 2.3:1 (With sealed pilot) 導壓室密封

3A : 3:1 (With sealed pilot) 導壓室密封

4A : 4.5:1 (With sealed pilot) 導壓室密封

10A : 10:1 (With sealed pilot) 導壓室密封

5 ADJUSTMENT OPTION 調整選擇

NONE	NONE:TOOL ADJUST 無:工具調整式	
C	C:TAMPER RESISTANT COVER C:防調封蓋	

◆ TECHNICAL FEATURES 技術特性

- Counterbalance valves should be set at least 1.3 time the maximum load induced pressure. 平衡閥的設定值應該至少為負載壓力值的1.3倍。
- Restrictive valves have no relief capacity other than as a thermal relief. 全限流洩壓量不足,但是具備熱洩功能。
- Reseat exceeds 85% of set pressure when the valve is standard set. Settings lower than the standard est pressure may result in lower reseal percentages. 標準設定下,閥的復位壓力值高於開啟值的85%。當設定值小於標準設定值,復位壓力值的百分比將相對變小。
- This valve has positive seals between all ports. 這種閥在所有的口之間都完全密封。

◆ DIMENSIONS 外型尺寸圖

