

◆ MODEL 型 式

VRB-02

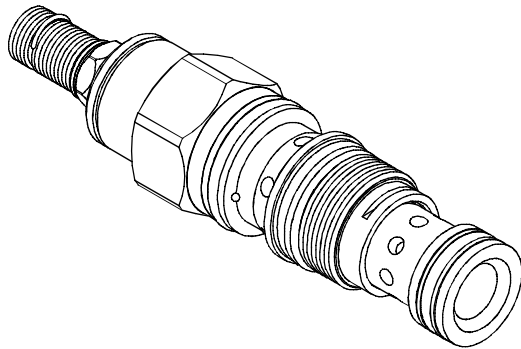

◆ PERFORMANCE 特性曲線

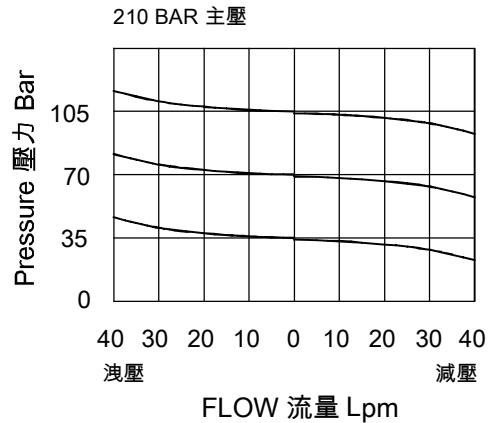

◆ SPECIFICATIONS 規 格

| Model Number 型式號碼 | Maximum Pressure 最大壓力 bar | Maximum Flow 最大流量 lpm | Weight 重量 Kg |
|-------------------------------|---------------------------|------------------------------|----------------|
| VRB-02 | 350 (5076psi) | 40 (10.57gpm) | 0.18 (0.4 lbs) |
| Fluid Type 流體型式 | | ISO VG 32, 46, 68 | |
| Viscosity 黏性 cSt | | 10~400 (59~1854 SSU) | |
| Operating Temperature 操作溫度 °C | | -15~70 (-5~158°F) | |
| Contamination Level 污染標準 | | ISO4406. 21/19/16 NAS1638,10 | |

◆ HOW TO ORDER 編號說明

| 1 | 2 | 3 | 4 | 5 |
|-----|----|---|---|---|
| VRB | 02 | * | * | * |

1 VALVE SERIES 系列名稱
 VRB=CARTRIDGE BALANCE VALVES
 (Pilot Operated Reducing/Relieving Valves)
 插入式平衡閥(導壓操作減泄壓閥)

2 SUBPLATE MOUNTING SIZE 稱呼口徑
 02 : T-11A
 Cavity 孔口: CST-11A
 See Page Appendixes-A_006
 見附錄 A_006 頁面

3 ADJUSTMENT PRESSURE 壓力調整範圍

| Order 編號 | Adjustment pressure 壓力調整範圍 |
|----------|----------------------------|
| 06 | 4 ~ 60 (bar) |
| 10 | 4 ~ 105 (bar) |
| 20 | 7 ~ 210 (bar) |
| 30 | 10 ~ 315 (bar) |

4 ADJUSTMENT OPTION 調整選擇

| | | |
|------|-------------------------------|--|
| NONE | NONE: TOOL ADJUST 無：工具調整式 | |
| K | K: HAND-BAR ADJUST K：手把調整式 | |

5 DESIGN NO 設計編號

◆ CONTROL PORT(S) 動作形式

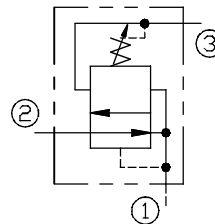

◆ DIMENSIONS 外型尺寸圖

