

◆ **MODEL** 型 式
VFD-03

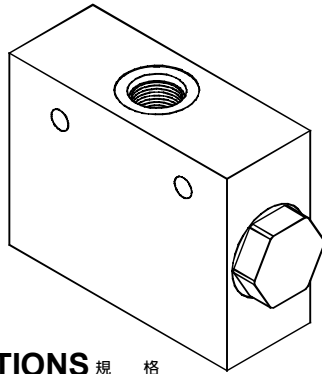

◆ **PERFORMANCE** 特性曲線

Test Conditions 測試條件
Oil Temperature 油溫度: 50°C (122°F)
Viscosity 黏性: 35 cSt (163 SSU)

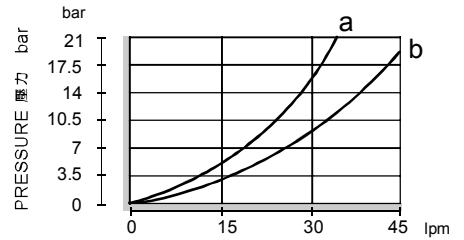

◆ **SPECIFICATIONS** 規 格

Model Number 型式號碼	Operating Pressure 操作壓力 bar	Flow 流量 lpm	Weight 重量 Kg
VFD-03	250 (3626 psi)	45 (11.89 gpm)	0.6 (1.32 lbs)
Fluid Type 流體型式		ISO VG 32, 46, 68	
Viscosity 黏性 cSt		10~400 (59~1854 SSU)	
Operating Temperature 操作溫度 °C		-30~100 (-22~212°F)	
Contamination Level 污染標準		ISO4406. 21/19/16 NAS1638,10	

◆ **HOW TO ORDER** 編號說明

1	2	3	4
VFD	03	— 07	— *

1 VALVE SERIES 系列名稱

VFD = FLOW DIVIDER Valves 分流閥

2 SUBPLATE MOUNTING SIZE 稱呼口徑

03 : G 3/8

3 FLOW SPECIFICATIONS 流量規格

07: 2.3~7.6 l/min	Division ratio: 50%-50%
15: 4.5~15 l/min	分流比例
22: 6.8~22.7 l/min	Flow Accuracy: 3% ~ 10%
30: 9~30 l/min	分流精度
37: 11~37 l/min	
45: 13.5~45 l/min	

◆ **CONTROL PORT(S)** 動作形式

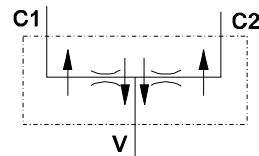

4 THREADED TYPE 螺紋規格

1P: PT	2N: NPT
3G: PF(G)	4A: SAE
5B: BSP	

◆ **DIMENSIONS**

外型尺寸圖

