

### ◆ MODEL 型式

VFD-04

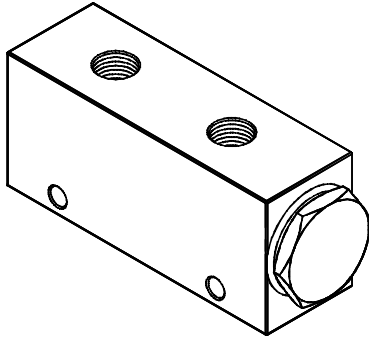

### ◆ PERFORMANCE 特性曲線

Test Conditions 測試條件

Oil Temperature 油溫度: 50°C (122°F)

Viscosity 黏性: 35 cSt (163 SSU)

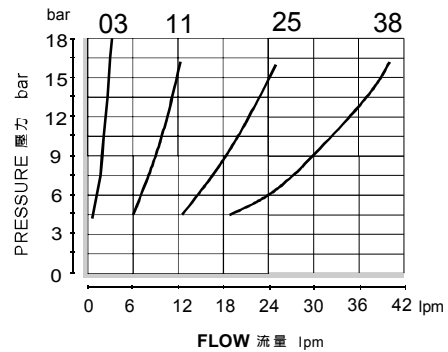

### ◆ SPECIFICATIONS 規格

Model Number 型式號碼	Operating Pressure 操作壓力 bar	Flow 流量 lpm	Weight 重量 Kg
VFD-04	250 (3626 psi)	38 (10.04 gpm)	0.8 (1.76 lbs)
Fluid Type 流體型式		ISO VG 32, 46, 68	
Viscosity 黏性 cSt		10~400 (59~1854 SSU)	
Operating Temperature 操作溫度 °C		-30~100 (-22~212°F)	
Contamination Level 污染標準		ISO4406. 21/19/16 NAS1638,10	

### ◆ HOW TO ORDER 編號說明

1	2	3	4
VFD	04	— 11 —	*

#### 1 VALVE SERIES 系列名稱

VFD = FLOW DIVIDER 分流閥

#### 2 SUBPLATE MOUNTING SIZE 稱呼口徑

04=1/2"

### ◆ CONTROL PORT(S) 動作形式

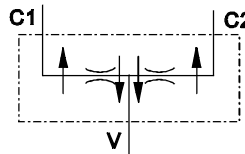

#### 3 FLOW SPECIFICATIONS 流量規格

03: 1~3 l/min 06: 2.8~6 l/min

11: 6.5~11 l/min 25: 10~25 l/min

38: 25~38 l/min

Division ratio: 50%-50%

分流比例

Flow Accuracy: ±3%

分流精度

#### 4 THREADED TYPE

螺紋規格

1P: PT

3G: PF(G)

5B: BSP

2N: NPT

4A: SAE

### ◆ DIMENSIONS 外型尺寸圖

外型尺寸圖

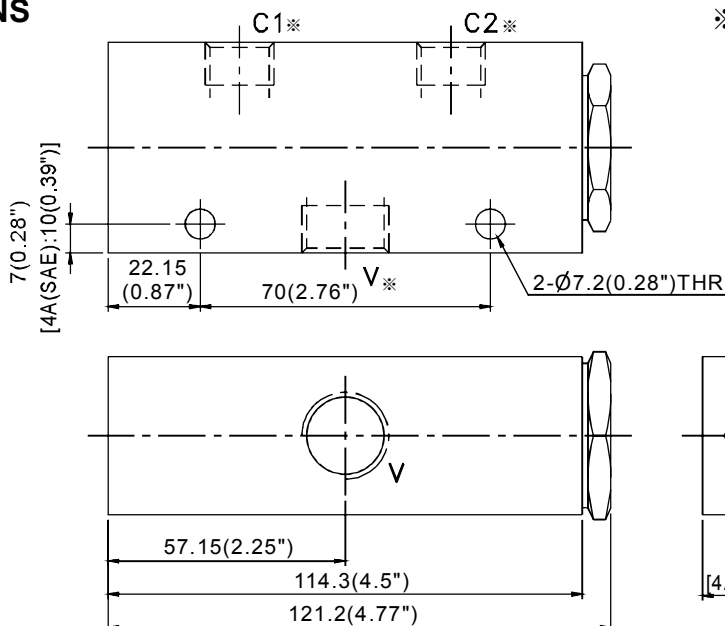

※ Flow Specifications 流量規格	C1	C2	V
03	1/4"	1/4"	3/8"
06	1/4"	1/4"	3/8"
11	3/8"	3/8"	1/2"
25	3/8"	3/8"	1/2"
38	3/8"	3/8"	1/2"