

◆ MODEL 型式

VNC-01

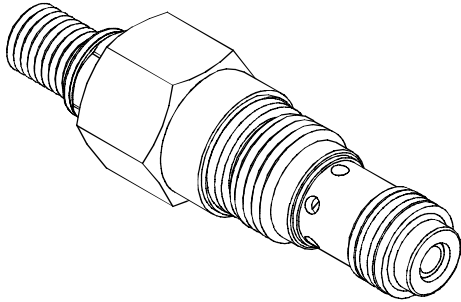

◆ PERFORMANCE (Cartridge Only)

特性曲線

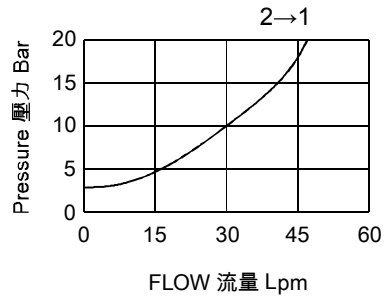

◆ SPECIFICATIONS 規格

Model Number 型式號碼	Maximum Pressure 最大壓力 bar	Maximum Flow 最大流量 Lpm	Control Flow 控制流量 Lpm	Weight 重量 Kg
VNC-01	350 (5076 psi)	40 (10.57 gpm)	15 (3.96 gpm)	0.1 (0.22 lbs)
Fluid Type 流體型式		ISO VG 32,46,68		
Viscosity 黏性 cSt		10~400 (59~1854SSU)		
Operating Temperature 操作溫度 °C		-30~100 (-22~212°F)		
Contamination Level 污染標準		ISO4406. 21/19/16 NAS1638,10		

◆ HOW TO ORDER 編號說明

1	2	3
VNC	01	*

1 VALVE SERIES 系列名稱

VNC=CARTRIDGE CHECK THROTTLE VALVES
插入式止逆節流閥

2 SUBPLATE MOUNTING SIZE 稱呼口徑

01 : T-162A
Cavity 孔口: CST-162A
See Page Appendixes-A_008
見附錄A_008頁面

3 ADJUSTMENT OPTION 調整選擇

NONE	NONE: TOOL ADJUST 無：工具調整式	
K	K: HAND-BAR ADJUST K：手把調整式	

◆ CONTROL PORT(S) 動作形式

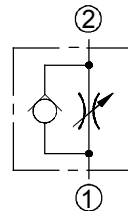

◆ DIMENSIONS 外型尺寸圖

