

◆ MODEL 型 式

VNC-03

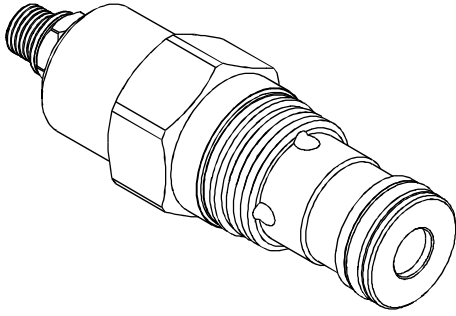

◆ PERFORMANCE (Cartridge Only)

特性曲線

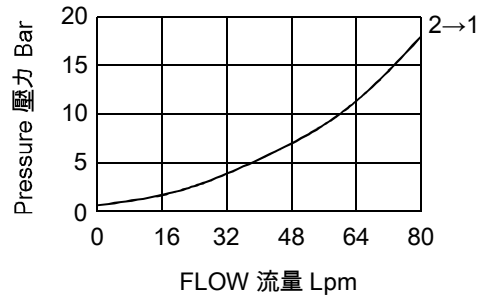

◆ SPECIFICATIONS 規 格

Model Number 型式號碼	Maximum Pressure 最大壓力 bar	Maximum Flow 最大流量 Lpm	Weight 重量 Kg
VNC-03	350 (5076 psi)	45 (11.89 gpm)	0.28 (0.62 lbs)
Fluid Type 流體型式		ISO VG 32,46,68	
Viscosity 黏性 cSt		10~400 (59~1854SSU)	
Operating Temperature 操作溫度 °C		-30~100 (-22~212°F)	
Contamination Level 污染標準		ISO4406. 21/19/16 NAS1638,10	

◆ HOW TO ORDER 編號說明

1	2	3	4	5
VNC	03	A	20	*

1 VALVE SERIES 系列名稱

VNC=CARTRIDGE CHECK THROTTLE VALVES
插入式止逆節流閥

2 SUBPLATE MOUNTING SIZE 稱呼口徑

03 : T-5A
Cavity 孔口: CST-5A
See Page Appendixes-A_006
見附錄A_006頁面

3 CONTROL FLOW 控制流量

A : 45 Lpm (11.89 gpm)
B : 11 Lpm (2.91 gpm)

4 BIAS SPRING 開啓壓力

20 : 2 bar (29psi)
50 : 5 bar (73psi)

5 ADJUSTMENT OPTION 調整選擇

NONE	NONE: TOOL ADJUST 無: 工具調整式	
K	K: HAND-BAR ADJUST K: 手把調整式	
KT	KT: HAND-BAR ADJUST (Three-winged) KT: 手把調整式(三翼)	

◆ CONTROL PORT(S) 動作形式

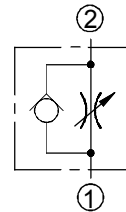

◆ DIMENSIONS 外型尺寸圖

