

FLOW CONTROL VALVES 流量控制閥

VT SERIES CARTRIDGE THROTTLE VALVES VT 系列插入式節流閥

◆ MODEL 型式

VT-02

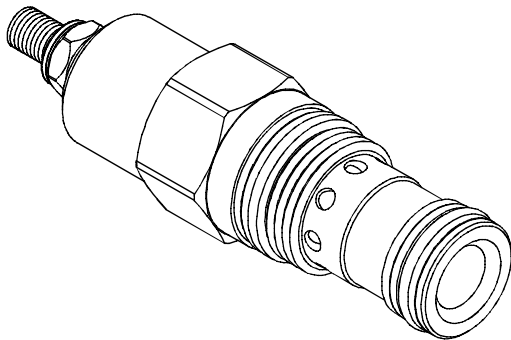

◆ PERFORMANCE(Cartridge Only) 特性曲線

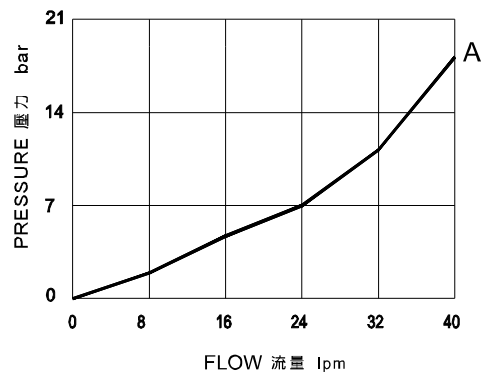

◆ SPECIFICATIONS 規格

Model Number 型式號碼	Maximum Pressure 最大壓力 bar	Maximum Flow 最大流量 Lpm	Weight 重量 Kg
VT-02	350 (5076 psi)	80 (21.13 gpm)	0.16 (0.35 lbs)
Fluid Type 流體型式		ISO VG 32,46,68	
Viscosity 黏性 cSt		10~400 (59~1854SSU)	
Operating Temperature 操作溫度 °C		-30~100 (-22~212°F)	
Contamination Level 污染標準		ISO4406. 21/19/16 NAS1638,10	

◆ HOW TO ORDER 編號說明

1	2	3	4	5
VT	02	A	— *	— *

1 VALVE SERIES 系列名稱

VT=CARTRIDGE THROTTLE VALVES
插入式節流閥

2 SUBPLATE MOUNTING SIZE 稱呼口徑

02 : T-13A
Cavity 孔口 : CST-13A
See Page Appendixes-A_006
見附錄A_006 頁面

3 FLOW SPECIFICATIONS 流量規格

A : 28 l/min
B : 80 l/min

4 ADJUSTMENT OPTION 調整選擇

NONE	NONE:TOOL ADJUST 無：工具調整式	
K	K:HAND-BAR ADJUST K：手把調整式	
KT	KT:HAND-BAR ADJUST (Three-winged) KT：手把調整式(三翼)	

5 DESIGN NO 設計編號

◆ CONTROL PORT(S) 動作形式

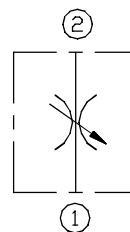

◆ DIMENSIONS 外型尺寸圖

