

◆ **MODEL 型 式**

VT-03

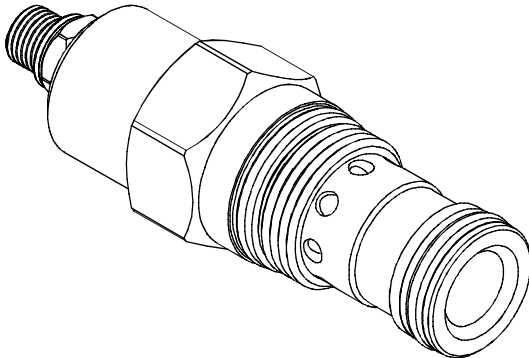

◆ **PERFORMANCE(Cartridge Only) 特性曲線**

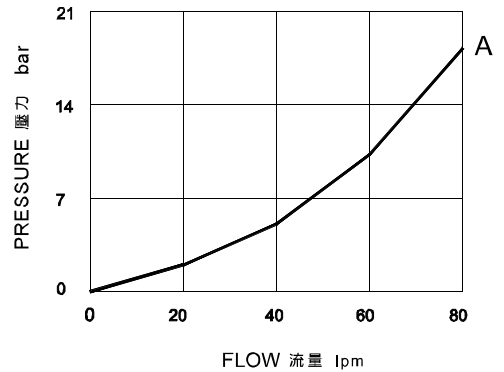

◆ **SPECIFICATIONS 規 格**

Model Number 型式號碼	Maximum Pressure 最大壓力 bar	Maximum Flow 最大流量 Lpm	Weight 重量 Kg
VT-03	350 (5076 psi)	200 (52.83 gpm)	0.3 (0.66 lbs)
Fluid Type 流體型式		ISO VG 32,46,68	
Viscosity 黏性 cSt		10~400 (59~1854SSU)	
Operating Temperature 操作溫度 °C		-30~100 (-22~212°F)	
Contamination Level 污染標準		ISO4406. 21/19/16 NAS1638,10	

◆ **HOW TO ORDER 編號說明**

1	2	3	4	5
VT	03	A	— *	— *

1 VALVE SERIES 系列名稱

VT=CARTRIDGE THROTTLE VALVES
插入式節流閥

2 SUBPLATE MOUNTING SIZE 稱呼口徑

03 : T-5A
Cavity 孔口 : CST-5A
See Page Appendixes-A_006
見附錄A_006 頁面

3 FLOW SPECIFICATIONS 流量規格

A : 45 l/min
B : 200 l/min

4 ADJUSTMENT OPTION 調整選擇

NONE	NONE:TOOL ADJUST 無：工具調整式	
K	K:HAND-BAR ADJUST K：手把調整式	
KT	KT:HAND-BAR ADJUST (Three-winged) KT：手把調整式(三翼)	

5 DESIGN NO 設計編號

◆ **CONTROL PORT(S) 動作形式**

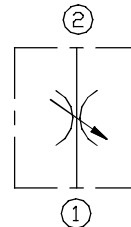

◆ **DIMENSIONS** 外型尺寸圖

