

◆ MODEL 型 式

VCK-01

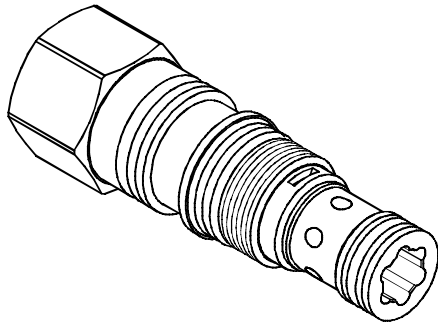

◆ PERFORMANCE 特性曲線

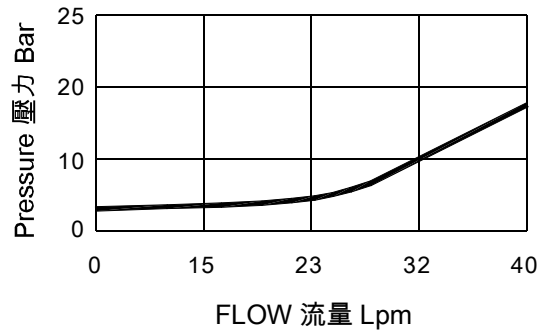

◆ SPECIFICATIONS 規 格

Model Number 型式號碼	Maximum Pressure 最大壓力 bar	Pilot Ratio 引導比例	Maximum Flow 最大流量 lpm	Weight 重量 Kg
VCK-01	350 (5076 psi)	3:1 / 4:1	30 (7.92 gpm)	0.13 (0.29 lbs)
Fluid Type 流體型式		ISO VG 32, 46, 68		
Viscosity 黏性 cSt		10~400 (59~1854 SSU)		
Operating Temperature 操作溫度 °C		-30~100 (-22~212°F)		
Contamination Level 污染標準		ISO4406. 21/19/16 NAS1638,10		

◆ HOW TO ORDER 編號說明

1	2	3	4
VCK	01	3A	20

◆ CONTROL PORT(S) 動作形式

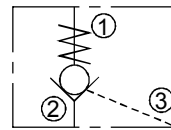

1 VALVE SERIES 系列名稱

VCK= CARTRIDGE PILOT OPERATED CHECK VALVES
插入式引導止逆閥

◆ DIMENSIONS 外型尺寸圖

2 SUBPLATE MOUNTING SIZE: 稱呼口徑

01:T-163A
Cavity 孔口:CST-163A
See Page Appendixes-A_008
見附錄A_008頁面

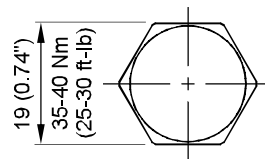

3 PILOT RATIO 引導比例

3A : 3 : 1
4A : 4 : 1

4 BIAS SPRING 開啓壓力

20 : 2 bar(29psi)
35 : 3.5 bar(51psi)

