

◆ **MODEL 型 式**  
**VCV-16**

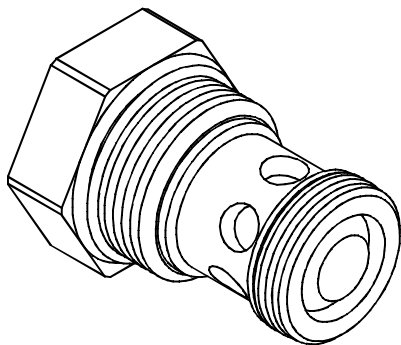

◆ **PERFORMANCE (Cartridge Only)**  
 特性曲線

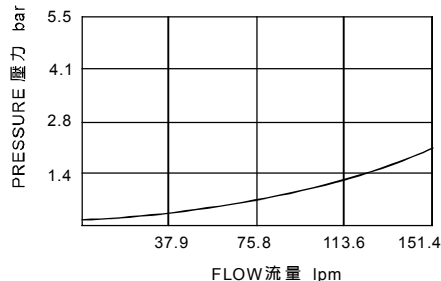

◆ **SPECIFICATIONS 規 格**

Model Number 型式號碼	Operating Pressure 操作壓力 bar	Flow 流量 lpm	Weight 重量 Kg
VCV-16	350 (5076psi)	150 (39.63 gpm)	0.26 (0.57 lbs)
<b>Fluid Type</b> 流體型式		ISO VG 32, 46, 68	
<b>Viscosity</b> 黏性 cSt		10~400 (59~1854 SSU)	
<b>Operating Temperature</b> 操作溫度 °C		-30~100 (-22~212°F)	
<b>Contamination Level</b> 污染標準		ISO4406. 21/19/16 NAS1638,10	

◆ **HOW TO ORDER 編號說明**

1	2	3	4
VCV	16	— 05	— 10

**1 VALVE SERIES** 系列名稱  
 VCV= Check Valves 止逆閥

**2 SUBPLATE MOUNTING SIZE** 稱呼口徑

Size:16  
 Cavity 孔口:CS16-2N  
 See Page Appendixes-A\_002  
 見附錄A\_002 頁面

**3 BIAS SPRING** 開啓壓力

- 05 : 0.35 bar (5psi)
- 20 : 2 bar (29psi)
- 50 : 4 bar (58psi)
- 80 : 8 bar (116psi)

**4 DESIGN NO** 設計編號

◆ **CONTROL PORT(S)** 動作形式

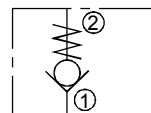

◆ **DIMENSIONS** 外型尺寸圖

