

### ◆ MODEL 型 式

VCV-20

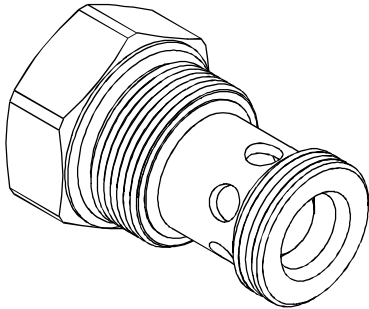

### ◆ PERFORMANCE (Cartridge Only) 特性曲線

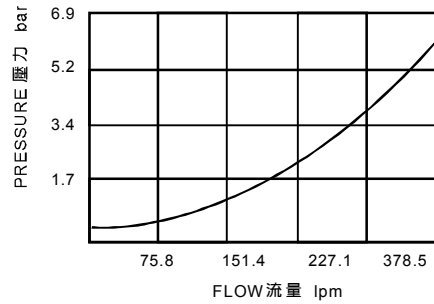

### ◆ SPECIFICATIONS 規 格

Model Number 型式號碼	Operating Pressure 操作壓力 bar	Flow 流量 lpm	Weight 重量 Kg
VCV-20	350 (5076psi)	379 (100.12 gpm)	0.43 (0.95 lbs)
Fluid Type 流體型式		ISO VG 32, 46, 68	
Viscosity 黏性 cSt		10~400 (59~1854 SSU)	
Operating Temperature 操作溫度 °C		-30~100 (-22~212°F)	
Contamination Level 污染標準		ISO4406. 21/19/16 NAS1638,10	

### ◆ HOW TO ORDER 編號說明

1	2	3	4
VCV	20	— 05	— 10

**1 VALVE SERIES** 系列名稱  
VCV= Check Valves 止逆閥

**2 SUBPLATE MOUNTING SIZE** 稱呼口徑

Size:20  
Cavity 孔口:CS20-2N  
See Page Appendixes-A\_002  
見附錄A\_002 頁面

**3 BIAS SPRING** 開啓壓力  
05 : 0.35 bar (5psi)  
50 : 4 bar (58psi)

**4 DESIGN NO** 設計編號

### ◆ CONTROL PORT(S) 動作形式

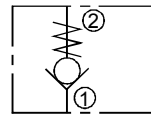

### ◆ DIMENSIONS 外型尺寸圖

