

### ◆ MODEL 型 式

VCVM-08

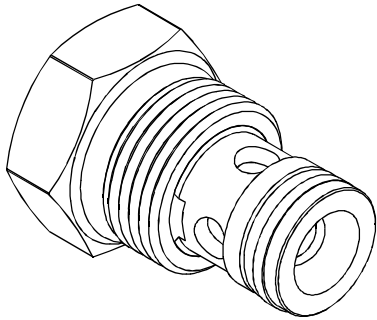

### ◆ PERFORMANCE (Cartridge Only) 特性曲線

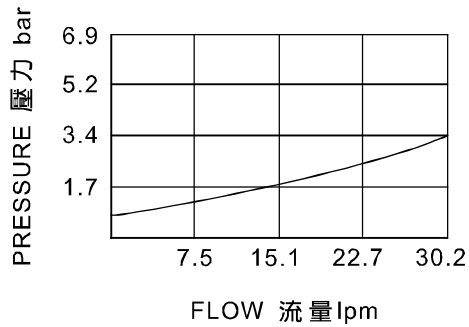

### ◆ SPECIFICATIONS 規 格

Model Number 型式號碼	Maximum Pressure 最大壓力 bar	Maximum Flow 最大流量 lpm	Weight 重量 Kg
VCVM-08	350 (5076 psi)	30 (7.93 gpm)	0.06 (0.13 lbs)
Fluid Type 流體型式		ISO VG 32, 46, 68	
Viscosity 黏性 cSt		10~400 (59~1854 SSU)	
Operating Temperature 操作溫度 °C		-15~70 (-5~158 °F)	
Contamination Level 污染標準		ISO4406. 21/19/16 NAS1638,10	

### ◆ HOW TO ORDER 編號說明

1	2	3	4
VCVM	08	—	05 — 10

#### 1 VALVE SERIES 系列名稱

VCVM= Check Valves 止逆閥

#### 2 SUBPLATE MOUNTING SIZE 稱呼口徑

Size:08  
Cavity 孔口: 06020  
See Page Appendixes-A\_001  
見附錄A\_001 頁面

#### 3 BIAS SPRING 開啓壓力

05 : 0.5 bar (7psi)  
20 : 2 bar (29psi)  
50 : 4 bar (58psi)

#### 4 DESIGN NO 設計編號

### ◆ CONTROL PORT(S) 動作形式

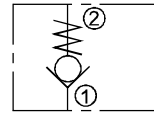

### ◆ DIMENSIONS 外型尺寸圖

