

### ◆ MODEL 型 式

VCX-02

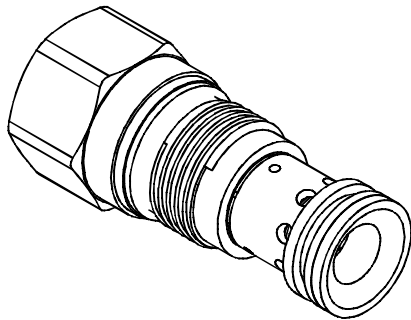

### ◆ PERFORMANCE (Cartridge Only)

特性曲線

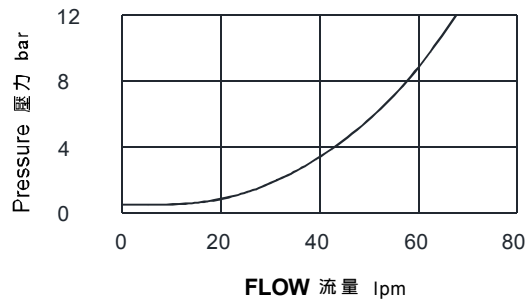

### ◆ SPECIFICATIONS 規 格

Model Number 型式號碼	Operating Pressure 操作壓力 bar	Flow 流量 lpm	Weight 重量 Kg
VCX-02	350 (5076 psi)	80 (21.13 gpm)	0.15 (0.33 lbs)
Fluid Type 流體型式		ISO VG 32, 46, 68	
Viscosity 黏性 cSt		10~400 (59~1854 SSU)	
Operating Temperature 操作溫度 °C		-30~100 (-22~212°F)	
Contamination Level 污染標準		ISO4406. 21/19/16 NAS1638,10	

### ◆ HOW TO ORDER 編號說明

1	2	3
VCX	02 —	05

#### 1 VALVE SERIES 系列名稱

VCX= Check Valves 止逆閥

#### 2 PORTING 閥口

02: T-13A

Cavity 孔口: CST-13A

See Page Appendixes-A\_006

見附錄A\_006 頁面

#### 3 BIAS SPRING 開啓壓力

05: 0.35 bar (5psi)

20: 2 bar (29psi)

50: 5 bar (73psi)

70: 7 bar (101.5psi)

### ◆ CONTROL PORT(S) 動作形式

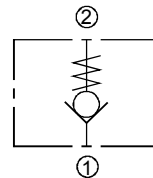

### ◆ DIMENSIONS 外型尺寸圖

