

◆ **MODEL 型 式**

**VCX-03**

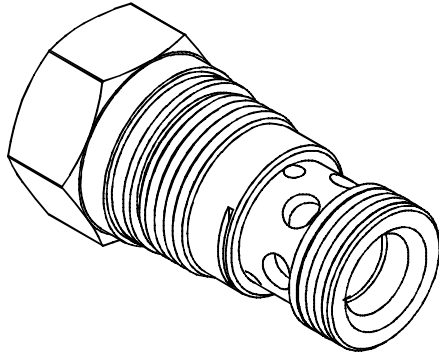

◆ **PERFORMANCE (Cartridge Only)**

特性曲線

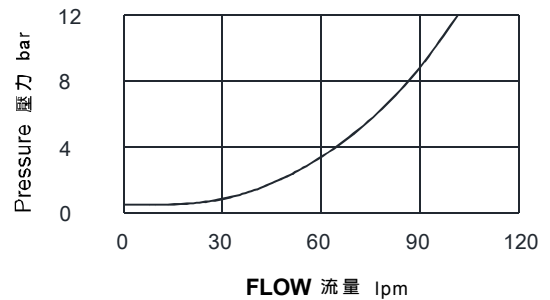

◆ **SPECIFICATIONS 規 格**

Model Number 型式號碼	Operating Pressure 操作壓力 bar	Flow 流量 lpm	Weight 重量 Kg
VCX-03	350 (5076 psi)	140 (36.98 gpm)	0.19 (0.42 lbs)
<b>Fluid Type</b> 流體型式		ISO VG 32, 46, 68	
<b>Viscosity</b> 黏性 cSt		10~400 (59~1854 SSU)	
<b>Operating Temperature</b> 操作溫度 °C		-30~100 (-22~212°F)	
<b>Contamination Level</b> 污染標準		ISO4406. 21/19/16 NAS1638,10	

◆ **HOW TO ORDER 編號說明**

1	2	3
<b>VCX</b>	<b>03</b>	<b>05</b>

**1 VALVE SERIES** 系列名稱  
VCX= Check Valves 止逆閥

**2 PORTING** 閥口  
03 : T-5A  
Cavity 孔口 : CST-5A  
See Page Appendixes-A\_006  
見附錄A\_006 頁面

**3 BIAS SPRING** 開啓壓力  
05 : 0.35 bar (5psi)  
10 : 1.1 bar (16psi)  
20 : 2 bar (29psi)  
50 : 5 bar (73psi)  
70 : 7 bar (101.5psi)  
100 : 10 bar (145psi)

◆ **CONTROL PORT(S) 動作形式**

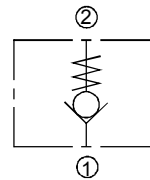

◆ **DIMENSIONS 外型尺寸圖**

