

◆ **MODEL 型 式**

VCX-10

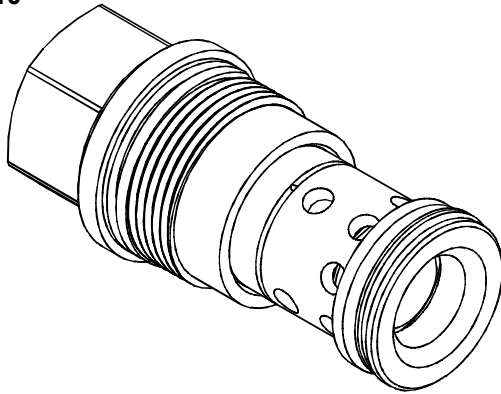

◆ **PERFORMANCE(Cartridge Only)**

特性曲線

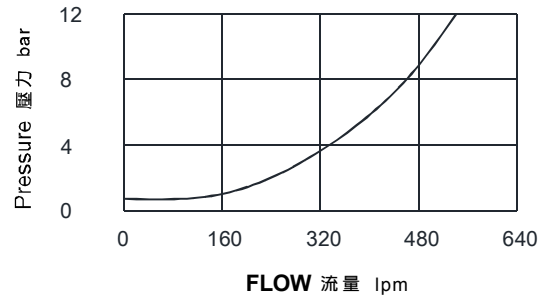

◆ **SPECIFICATIONS 規 格**

Model Number 型式號碼	Operating Pressure 操作壓力 bar	Flow 流量 lpm	Weight 重量 Kg
VCX-10	350 (5076 psi)	640 (169.07 gpm)	1.3 (2.87 lbs)
Fluid Type 流體型式		ISO VG 32, 46, 68	
Viscosity 黏性 cSt		10~400 (59~1854 SSU)	
Operating Temperature 操作溫度 °C		-30~100 (-22~212°F)	
Contamination Level 污染標準		ISO4406. 21/19/16 NAS1638,10	

◆ **HOW TO ORDER 編號說明**

1	2	3
VCX	10	05

1 VALVE SERIES 系列名稱
VCX= Check Valves 止逆閥

2 PORTING 閥口
10: T-18A
Cavity 孔口: CST-18A
See Page Appendixes-A_007
見附錄A_007 頁面

3 BIAS SPRING 開啓壓力
03: 0.3 bar (4.35psi)
05: 0.5 bar (7psi)
20: 2 bar (29psi)
50: 5 bar (73psi)

◆ **CONTROL PORT(S) 動作形式**

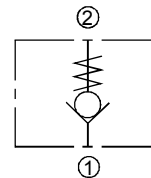

◆ **DIMENSIONS 外型尺寸圖**

