

◆ MODEL 型 式

VCXE-01

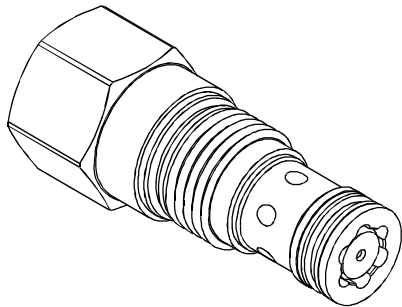

◆ PERFORMANCE (Cartridge Only)

特性曲線

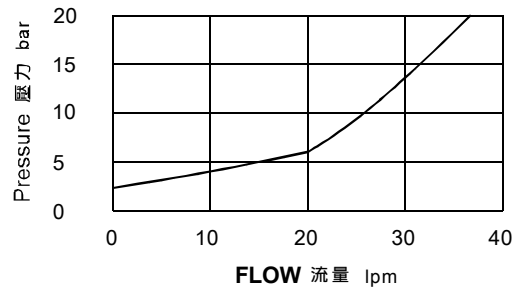

◆ SPECIFICATIONS 規 格

Model Number 型式號碼	Operating Pressure 操作壓力 bar	Flow 流量 lpm	Weight 重量 Kg
VCXE-01	350 (5076psi)	30 (7.92 gpm)	0.1 (0.22 lbs)
Fluid Type 流體型式		ISO VG 32, 46, 68	
Viscosity 黏性 cSt		10~400 (59~1854 SSU)	
Operating Temperature 操作溫度 °C		-30~100 (-22~212°F)	
Contamination Level 污染標準		ISO4406. 21/19/16 NAS1638,10	

◆ HOW TO ORDER 編號說明

1	2	3
VCXE	01 —	20

1 VALVE SERIES 系列名稱

VCXE= Check Valves 止逆閥

2 PORTING 閥口

01 : T-162A

Cavity 孔口 : CST-162A

See Page Appendixes-A_008

見附錄A_008 頁面

3 BIAS SPRING 開啓壓力

20 : 2 bar (29psi)

35 : 3.5 bar (51psi)

◆ CONTROL PORT(S) 動作形式

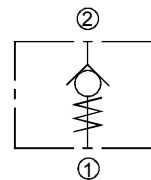

◆ DIMENSIONS 外型尺寸圖

