

◆ **MODEL** 型 式

VCXE-06

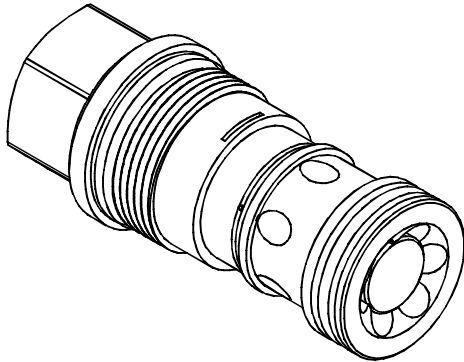

◆ **PERFORMANCE**(Cartridge Only)

特性曲線

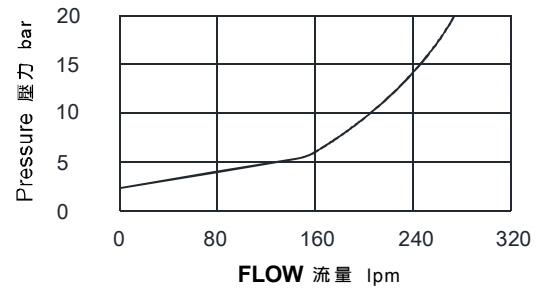

◆ **SPECIFICATIONS** 規 格

Model Number 型式號碼	Operating Pressure 操作壓力 bar	Flow 流量 lpm	Weight 重量 Kg
VCXE-06	350 (5076 psi)	240 (63.40 gpm)	0.63 (1.39 lbs)
Fluid Type 流體型式		ISO VG 32 , 46 , 68	
Viscosity 黏性 cSt		10~400 (59~1854 SSU)	
Operating Temperature 操作溫度 °C		-30~100 (-22~212°F)	
Contamination Level 污染標準		ISO4406. 21/19/16 NAS1638,10	

◆ **HOW TO ORDER** 編號說明

1	2	3
VCXE	06	05

1 VALVE SERIES 系列名稱
VCXE= Check Valves 止逆閥

2 PORTING 閥口
06 : T-16A
Cavity 孔口 : CST-16A
See Page Appendixes-A_007
見附錄A_007 頁面

3 BIAS SPRING 開啓壓力
05 : 0.35 bar (5psi)
20 : 2 bar (29psi)
50 : 5 bar (73psi)

◆ **CONTROL PORT(S)** 動作形式

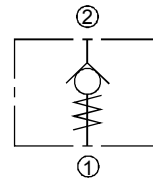

◆ **DIMENSIONS** 外型尺寸圖

