

◆ MODEL 型 式 VLS-02

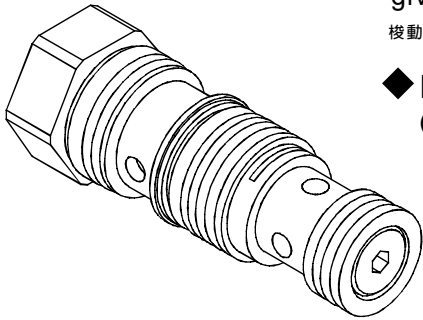

◆ DESCRIPTION 說 明

Shuttle Valves, cartridge-style hydraulic check valve, for use in blocking circuits where a priority of flow/direction is given to a higher pressure circuit over a lower one.

梭動閥，插入式油壓止逆閥，在流量/方向被優先供應至較高的壓力迴路時，用於阻擋低壓迴路。

◆ PERFORMANCE 特性曲線 (Cartridge Only)

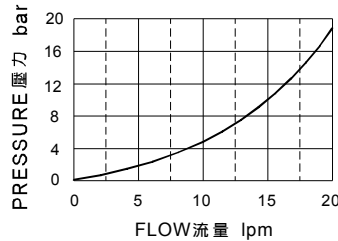

◆ SPECIFICATIONS 規 格

Model Number 型式號碼	Operating Pressure 操作壓力 bar	Flow 流量 lpm	Weight 重量 Kg
VLS-02	350 (5076psi)	10 (2.64 gpm)	0.14 (0.31 lbs)
Fluid Type 流體型式		ISO VG 32, 46, 68	
Viscosity 黏性 cSt		10~400 (59~1854 SSU)	
Operating Temperature 操作溫度 °C		-15~70 (-5~158 °F)	
Contamination Level 污染標準		ISO4406. 21/19/16 NAS1638,10	

◆ HOW TO ORDER 編號說明

1	2
VLS	02

1 VALVE SERIES 系列名稱

VLS= CARTRIDGE SHUTTLE VALVES
插入式梭動閥

2 SUBPLATE MOUNTING SIZE 稱呼口徑

02:T-11A
Cavity 孔口:CST-11A
See Page Appendixes-A_006
見附錄A_006頁面

◆ CONTROL PORT(S) 動作形式

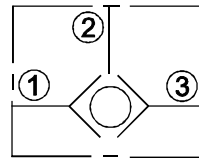

◆ DIMENSIONS 外型尺寸圖

