

◆ MODEL 型 式

VLSB-02

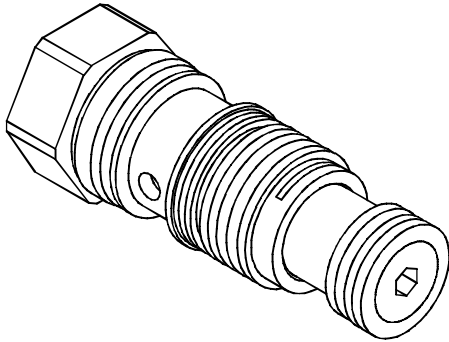

◆ PERFORMANCE 特性曲線

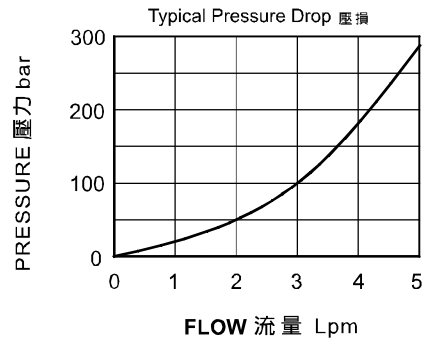

◆ SPECIFICATIONS 規 格

Model Number 型式號碼	Operating Pressure 操作壓力 bar	Flow 流量 lpm	Weight 重量 Kg
VLSB-02	350 (5076 psi)	10 (2.64 gpm)	0.14 (0.31 lbs)
Fluid Type 流體型式		ISO VG 32,46,68	
Viscosity 黏性 cSt		10~400 (59~1854SSU)	
Operating Temperature 操作溫度 °C		-15~70 (-5~158°F)	
Contamination Level 污染標準		ISO4406. 21/19/16 NAS1638,10	

◆ HOW TO ORDER 編號說明

1	2
VLSB	02

1 VALVE SERIES 系列名稱

VLSB= CARTRIDGE SHUTTLE VALVES
插入式梭動閥

2 SUBPLATE MOUNTING SIZE 稱呼口徑

02 :T-11A
Cavity 孔口:CST-11A
See Page Appendixes-A_006
見附錄A_006頁面

◆ CONTROL PORT(S) 動作形式

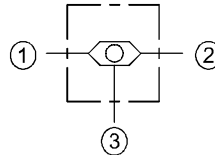

◆ DIMENSIONS 外型尺寸圖

