

◆ **MODEL 型 式**  
VLSD-02

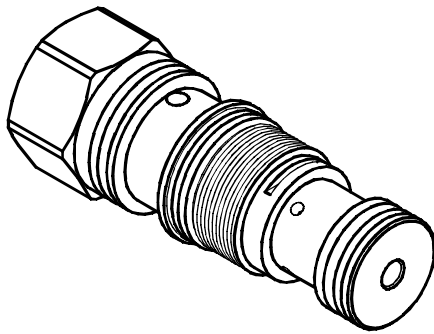

◆ **PERFORMANCE 特性曲線**

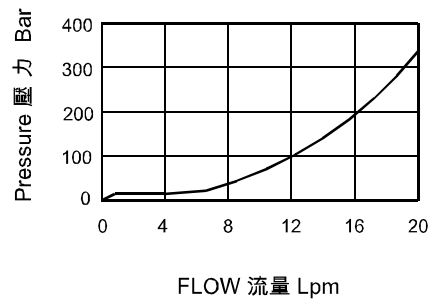

◆ **SPECIFICATIONS 規 格**

Model Number 型式號碼	Operating Pressure 操作壓力 bar	Flow 流量 lpm	Weight 重量 Kg
VLSD-02	350 (5076 psi)	10 (2.64 gpm)	0.13 (0.26 lbs)
<b>Fluid Type</b> 液體型式		ISO VG 32, 46, 68	
<b>Viscosity</b> 黏性 cSt		10~400 (59~1854 SSU)	
<b>Operating Temperature</b> 操作溫度 °C		-15~70 (-5~158 °F)	
<b>Contamination Level</b> 污染標準		ISO4406. 21/19/16 NAS1638,10	

◆ **HOW TO ORDER 編號說明**

<b>1</b>	<b>2</b>
VLSD	02

**1 VALVE SERIES 系列名稱**

VLSD= CARTRIDGE SHUTTLE VALVES  
插入式梭動閥

**2 SUBPLATE MOUNTING SIZE 稱呼口徑**

02:T-11A  
Cavity 孔口:CST-11A  
See Page Appendixes-A\_006  
見附錄 A\_006 頁面

◆ **CONTROL PORT(S) 動作形式**

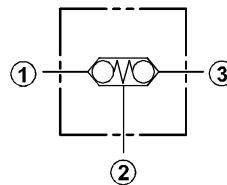

◆ **DIMENSIONS 外型尺寸圖**

