

### ◆ MODEL 型 式

VLSL-03

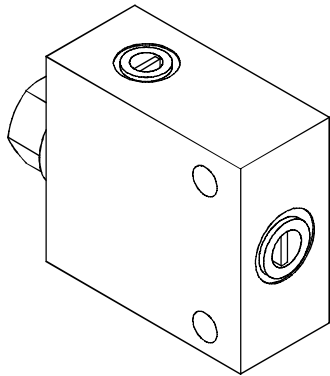

### ◆ DESCRIPTION 說明

Shuttle Valves, cartridge-style hydraulic check valve, for use in blocking circuits where a priority of flow/direction is given to a higher pressure circuit over a lower one. a load-shutting.

插入型式梭動閥，在優先的流量/方向的地方給予較高壓力電路超過較低的一方時，便會關閉電路。

### ◆ PERFORMANCE 特性曲線

(Cartridge Only)

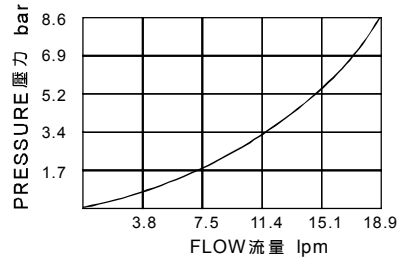

### ◆ SPECIFICATIONS 規格

Model Number 型式號碼	Maximum Pressure 最大壓力 bar	Flow 流量 lpm	Weight 重量 Kg
VLSL-03	350 (5076psi)	19 (5.02 gpm)	1.07 (2.36 lbs)
Fluid Type 流體型式		ISO VG 32, 46, 68	
Viscosity 黏性 cSt		10~400 (59~1854 SSU)	
Operating Temperature 操作溫度 °C		-30~100 (-22~212°F)	
Contamination Level 污染標準		ISO4406. 20/18/15 NAS1638. 9	

### ◆ HOW TO ORDER 編號說明

1	2	3	4
VLSL	03	— *	— *



Body Material 閥體材質	Maximum Pressure 最大壓力 bar	Weight 重量 Kg
Aluminum (standard) 鋁 (標準)	260 (3771 psi)	0.42 (0.93 lbs)
Nodular Ductile-Iron 球墨鑄鐵	350 (5076 psi)	1.07 (2.36 lbs)

### 1 VALVE SERIES 系列名稱

VLSL = Shuttle Valves 梭動閥

### 2 PORTING 閥口

03=3/8

### 3 THREADED TYPE 螺紋規格

1P: PT      3G: PF(G)  
2N: NPT    4A: SAE    5B: BSP

### 4 BODY MATERIAL 閥體材質

NONE (Standard): Aluminum-alloy 無 (標準): 鋁合金  
D: Nodular Ductile-Iron 球墨鑄鐵

### ◆ CONTROL PORT(S) 動作形式

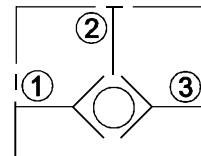

### ◆ DIMENSIONS 外型尺寸圖

外型尺寸圖

