

◆ MODEL 型式 VPC-10

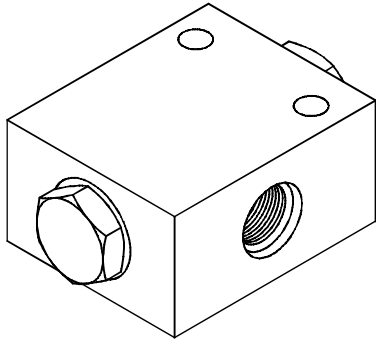

◆ PERFORMANCE 特性曲線 (Cartridge Only)

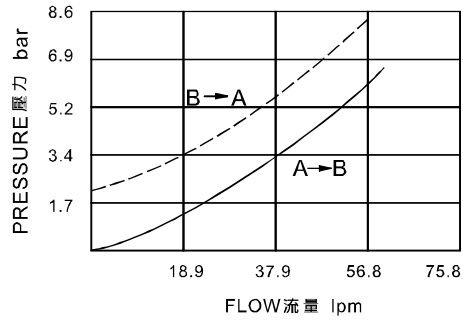

◆ SPECIFICATIONS 規格

Model Number 型式號碼	Operating Pressure 操作壓力 bar	Pilot Ratio 引導比例	Flow 流量 lpm	Weight 重量 Kg
VPC-10	350 (5076 psi)	6:1	70 (18.49 gpm)	2.2 (4.85 lbs)
Fluid Type 流體型式		ISO VG 32, 46, 68		
Viscosity 黏性 cSt		10~400 (59~1854 SSU)		
Operating Temperature 操作溫度 °C		-15~70 (-5~158 °F)		
Contamination Level 污染標準		ISO4406. 21/19/16 NAS1638,10		

◆ HOW TO ORDER 編號說明

1	2	3	4
VPC	10	*	10

1 VALVE SERIES 系列名稱

VPC = PILOT OPERATED CHECK VALVES
引導式止逆閥

2 PORTING 閥口

1/2

3 THREADED TYPE 螺紋規格

1P: PT 2N: NPT 3G: PF(G)
4A: SAE 5B: BSP

4 DESIGN NO 設計編號

◆ CONTROL PORT(S) 動作形式

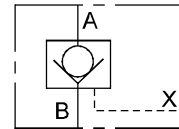

◆ DIMENSIONS 外型尺寸圖

外型尺寸圖

