

◆ **MODEL** 型 式

VPC-16

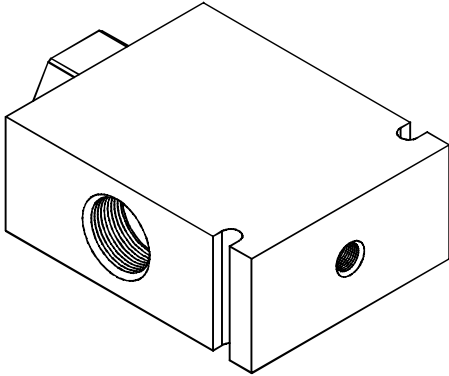

◆ **PERFORMANCE** 特性曲線
(Cartridge Only)

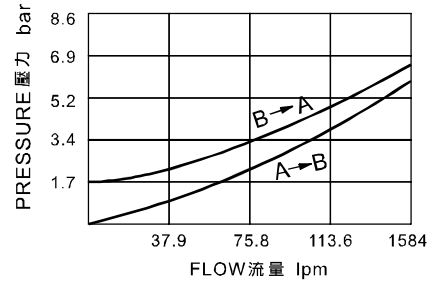

◆ **SPECIFICATIONS** 規 格

Model Number 型式號碼	Operating Pressure 操作壓力 bar	Pilot Ratio 引導比例	Flow 流量 lpm	Weight 重量 Kg
VPC-16	350 (5076psi)	3.8:1	150 (39.63 gpm)	5.8 (12.79 lbs)
Fluid Type 流體型式		ISO VG 32, 46, 68		
Viscosity 黏性 cSt		10~400 (59~1854 SSU)		
Operating Temperature 操作溫度 °C		-15~70 (-5~158°F)		
Contamination Level 污染標準		ISO4406. 21/19/16 NAS1638,10		

◆ **HOW TO ORDER** 編號說明

1	2	3	4
VPC	16	*	10

1 VALVE SERIES 系列名稱
VPC = PILOT OPERATED CHECK VALVES
引導式止逆閥

2 PORTING 閥口
1"

3 THREADED TYPE 螺紋規格
1P: PT 2N: NPT 3G: PF(G)
4A: SAE 5B: BSP

4 DESIGN NO 設計編號

◆ **CONTROL PORT(S)** 動作形式

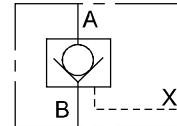

◆ **DIMENSIONS**

外型尺寸圖

