

◆ MODEL 型 式

VPCT-08

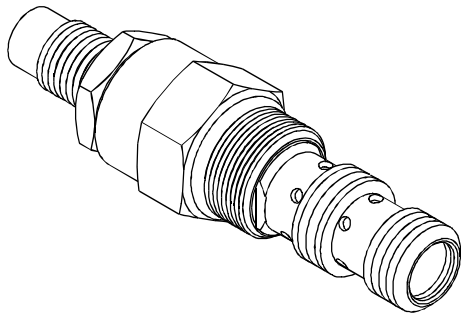

◆ PERFORMANCE 特性曲線 (Cartridge Only)

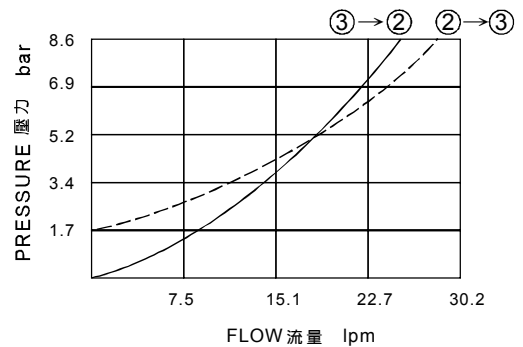

◆ SPECIFICATIONS 規 格

Model Number 型式號碼	Operating Pressure 操作壓力 bar	Flow 流量 lpm	Weight 重量 Kg
VPCT-08	250 (3626 psi)	23 (6.08 gpm)	0.16 (0.35 lbs)
Fluid Type 流體型式		ISO VG 32 , 46 , 68	
Viscosity 黏性 cSt		10~400 (59~1854 SSU)	
Operating Temperature 操作溫度 °C		-30~100 (-22~212°F)	
Contamination Level 污染標準		ISO4406. 21/19/16 NAS1638,10	

◆ HOW TO ORDER 編號說明

1	2	3
VPCT	08	30

1 VALVE SERIES 系列名稱

VPCT = CARTRIDGE PILOT OPERATED CHECK VALVES
(INCLUDE AN OPENING TO FLOW & PRESSURE ADJUSTMENT LEVER)
插入式引導止逆閥(附開口流量與壓力調整桿)

2 PORTING 閥口

Size:08
Cavity 孔口:CS08-3N
See Page Appendixes-A_002
見附錄A_002 頁面

3 DESIGN NO 設計編號

◆ CONTROL PORT(S) 動作形式

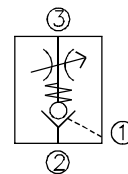

◆ DIMENSIONS 外型尺寸圖

