

◆ **MODEL 型式**
VPK-08M

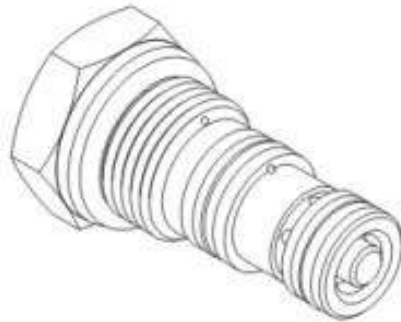

◆ **PERFORMANCE (Cartridge Only)**
特性曲線

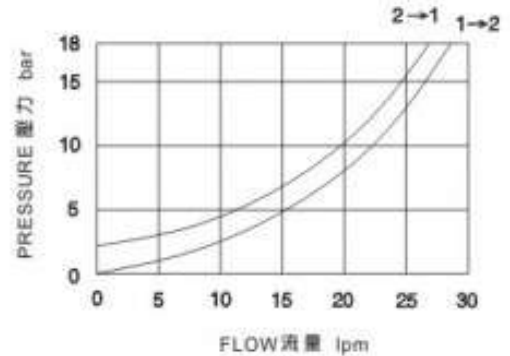

◆ **SPECIFICATIONS 規格**

Model Number 型式號碼	Maximum Pressure 最大壓力 bar	Open Pressure 開啟壓力 bar	Pilot Ratio 引導比例	Maximum Flow 最大流量 Lpm	Weight 重量 Kg
VPK-08M	350 (5076 psi)	2 (29 psi)	3:1	30 (7.93 gpm)	0.12 (0.27 lbs)
Fluid Type 液體型式			ISO VG 32,46,68		
Viscosity 黏性 cSt			10-400 (59-1854SSU)		
Operating Temperature 操作溫度 °C			-15-70 (-5-158°F)		
Contamination Level 污染標準			ISO4406. 21/19/16 NAS1638,10		

◆ **HOW TO ORDER 編號說明**

1 **2** **3**
VPK 08M — *

1 VALVE SERIES 系列名稱
VPK=CARTRIDGE PILOT OPERATED CHECK VALVES
插入式引導止逆閥

2 SUBPLATE MOUNTING SIZE 轉印口徑
Size : 08
Cavity 孔口 : A6610

3 DESIGN NO 設計編號

◆ **CONTROL PORT(S) 動作形式**

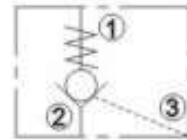

◆ **DIMENSIONS 外型尺寸圖**

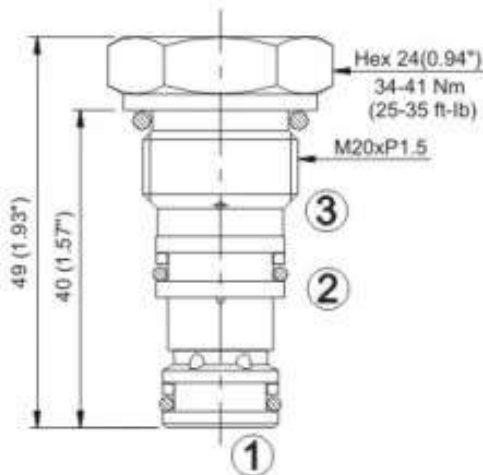

◆ **CAVITIES DIMENSIONS 孔口尺寸圖**

