

◆ MODEL 型式

VPK-10

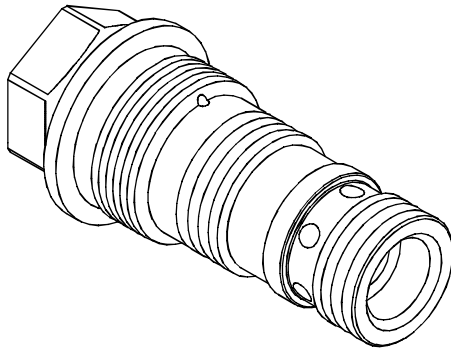

◆ PERFORMANCE (Cartridge Only)

特性曲線

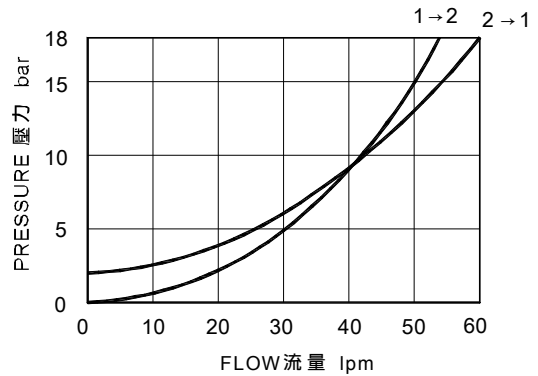

◆ SPECIFICATIONS 規格

Model Number 型式號碼	Maximum Pressure 最大壓力 bar	Cracking Pressure 開啟壓力 bar	Pilot Ratio 引導比例	Maximum Flow 最大流量 Lpm	Weight 重量 Kg
VPK-10	350 (5076 psi)	2 (29 psi)	3.2 : 1	60 (15.85 gpm)	0.15 (0.33 lbs)
Fluid Type 流體型式			ISO VG 32,46,68		
Viscosity 黏性 cSt			10~400 (59~1854SSU)		
Operating Temperature 操作溫度 °C			-15~70 (-5~158°F)		
Contamination Level 污染標準			ISO4406. 21/19/16 NAS1638,10		

◆ HOW TO ORDER 編號說明

1	2	3
VPK	10	*

1 VALVE SERIES 系列名稱

VPK=CARTRIDGE PILOT
OPERATED CHECK VALVES
插入式引導止逆閥

2 SUBPLATE MOUNTING SIZE 稱呼口徑

Size : 10
Cavity 孔口: CS10-3S
See Page Appendixes-A_003
見附錄A_003 頁面

3 DESIGN NO 設計編號

◆ CONTROL PORT(S) 動作形式

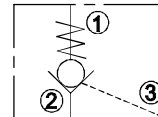

◆ DIMENSIONS 外型尺寸圖

