

### ◆ MODEL 型 式

VPN-10

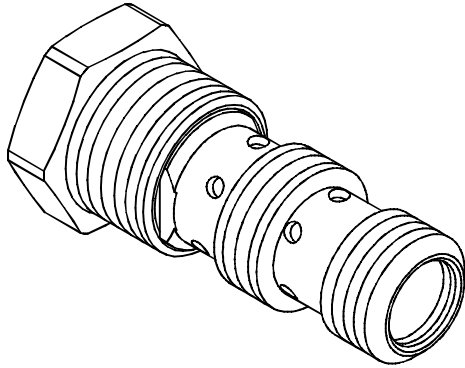

### ◆ PERFORMANCE 特性曲線 (Cartridge Only)

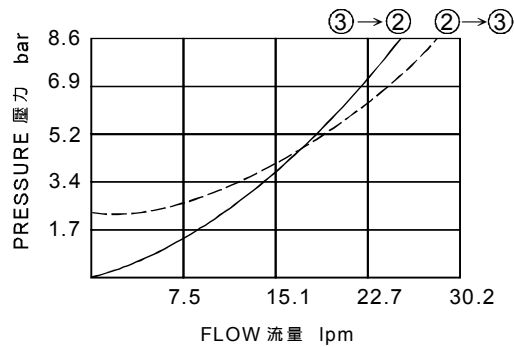

### ◆ SPECIFICATIONS 規 格

Model Number 型式號碼	Maximum Pressure 最大壓力 bar	Operating Pressure 操作壓力 bar	Pilot Ratio 引導比例	Flow 流量 lpm	Weight 重量 Kg
VPN-10	350 (5076psi)	250 (3626 psi)	4:1	25 (6.60 gpm)	0.1 (0.22 lbs)
<b>Fluid Type</b> 流體型式			ISO VG 32, 46, 68		
<b>Viscosity</b> 黏性 cSt			10~400 (59~1854 SSU)		
<b>Operating Temperature</b> 操作溫度 °C			-30~100 (-22~212°F)		
<b>Contamination Level</b> 污染標準			ISO4406. 21/19/16 NAS1638,10		

### ◆ HOW TO ORDER 編號說明

1	2	3	4
VPN	10	*	*

#### 1 VALVE SERIES 系列名稱

VPN = CARTRIDGE PILOT OPERATED CHECK VALVES  
插入式引導止逆閥

#### 2 PORTING 閥口

Size:10  
Cavity 孔口:CS10-3N  
See Page Appendixes-A\_002  
見附錄A\_002 頁面

#### 3 Cracking Pressure 開啓壓力

05 : 0.5 bar (7psi)  
10 : 1 bar (14psi)  
20 : 2 bar (29psi)  
50 : 5 bar (72psi)

● The seal kit of the pilot piston has a minimum spring pressure of 2 bar.

導壓活塞帶密封件最低彈簧壓力為2bar.

#### 4 SEALS 密封件

Non : NBR (Standard) 無記號 : 丁腈橡膠(標準型)  
HN : HNBR HN : 氫化丁腈橡膠  
V : VITON V : 氟橡膠

### ◆ CONTROL PORT(S) 動作形式

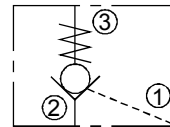

### ◆ DIMENSIONS 外型尺寸圖

