

◆ MODEL 型 式

VPW-10

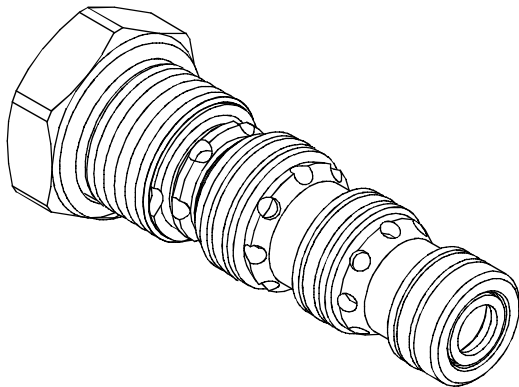

◆ PERFORMANCE 特性曲線

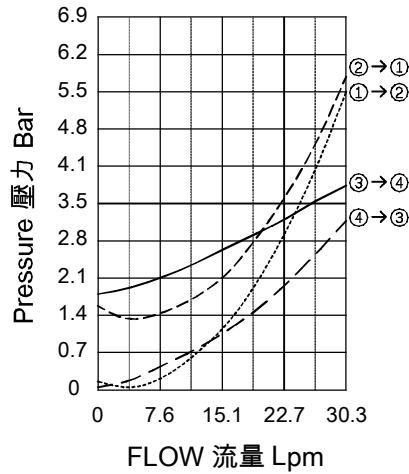

◆ SPECIFICATIONS 規 格

Model Number 型式號碼	Maximum Pressure 最大壓力 bar	Cracking Pressure 開啟壓力 bar	Pilot Ratio 引導比例	Maximum Flow 最大流量 lpm	Weight 重量 Kg
VPW-10	240 (3481psi)	1.7 (25 psi)	3:1	31 (8.19 gpm)	0.13 (0.29 lbs)
Fluid Type 流體型式			ISO VG 32 , 46 , 68		
Viscosity 黏性 cSt			10~400 (59~1854 SSU)		
Operating Temperature 操作溫度 °C			-30~100 (-22~212°F)		
Contamination Level 污染標準			ISO4406. 20/18/15 NAS1638. 9		

◆ HOW TO ORDER 編號說明

1	2	3	4
VPW	10	3A	*

1 VALVE SERIES 系列名稱

VPW= Cartridge Pilot Operated Check Valves
插入式引導止逆閥

2 SUBPLATE MOUNTING SIZE 稱呼口徑

Size : 10
Cavity 孔口:CS10-4N
See Appendixes-A 見附錄A
For Manifold See Appendixes-B 油路板見附錄B

3 PILOT RATIO 引導比例

3A: 3:1

4 DESIGN NO 設計編號

◆ CONTROL PORT(S) 動作形式

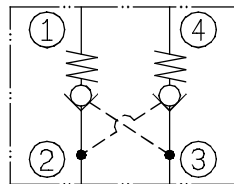

◆ DIMENSIONS 外型尺寸圖

