

# SOLENOID OPERATED CARTRIDGE VALVES

插入式電磁閥

## VSE SERIES CARTRIDGE TYPE SOLENOID OPERATED CHECK VALVES

VSE 系列插入式電磁止逆閥

### ◆ MODEL 型式

VSE12-20-GIV

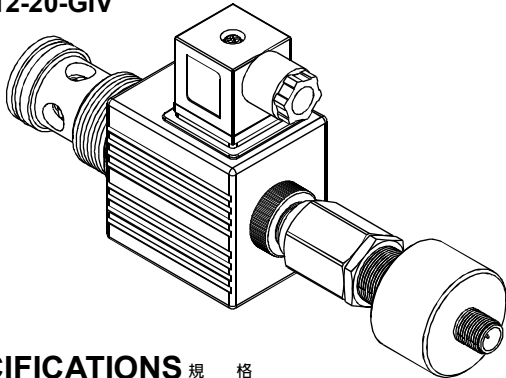

### ◆ PERFORMANCE 特性曲線

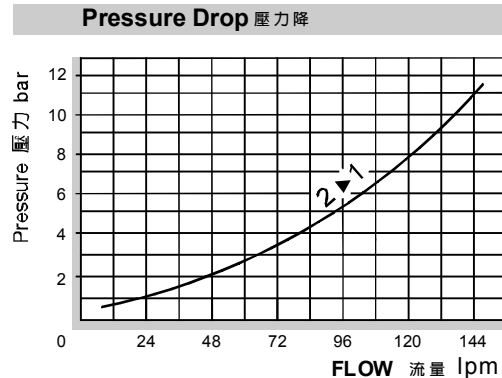

### ◆ SPECIFICATIONS 規格

Model Number 型式號碼	Maximum Pressure 最大壓力 bar	Maximum Flow 最大流量 lpm	Weight 重量 Kg
VSE12-20-GIV	350 (5076 psi)	150 (39.63 gpm)	0.96 (2.12 lbs)
<b>Fluid Type 流體型式</b>		ISO VG 32, 46, 68	
<b>Viscosity 黏性 cSt</b>		10~400 (59~1854 SSU)	
<b>Operating Temperature 操作溫度 °C</b>		-30~100 (-22~212°F)	
<b>Contamination Level 污染標準</b>		ISO4406. 21/19/16 NAS1638,10	

### ◆ HOW TO ORDER 編號說明

1	2	3	4	5	6				
VSE	12	—	20	—	A2	—	*	—	GIV

#### 1 VALVE SERIES 系列名稱

VSE=Cartridge Type Solenoid Operated Check Valves 插入式電磁止逆閥

#### 2 SUBPLATE MOUNTING SIZE 稱呼口徑

12 : E-021  
Cavity 孔口: CSE 021-2N  
See Page Appendixes-A\_001  
見附錄A\_001 頁面

#### 3 CONTROL PORT(S) 動作形式

20 :

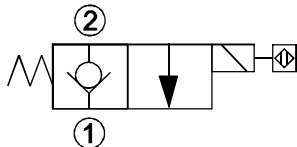

#### 4 TYPE OF COIL 線圈類型

Non : Without Coil 無記號:無線圈

A1 : RAC110V 60/50HZ      D1 : DC12V  
A2 : RAC220V 60/50HZ      D2 : DC24V

#### 5 WIRING TYPE 接線型式

Non:WIRING BOX TYPE(DIN)      X : DOUBLE LEAD  
無:接線盒式 (DIN)                  雙接線方式

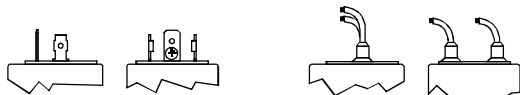

※ For more technical information of wiring type please refer to the appendixes-D or contact with us .  
接線型式的詳細技術資料請查附錄-D或與我們聯繫。

#### 6 DESIGN NO 設計編號

GIV :Position Switch Included

附位置感應器

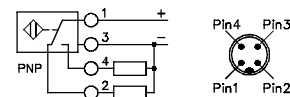

### ◆ DIMENSIONS 外型尺寸圖

