

### ◆ MODEL 型式

VSE12-22

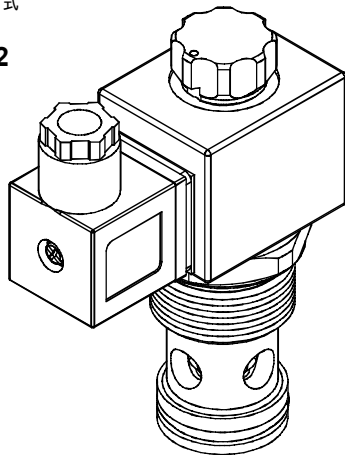

### ◆ PERFORMANCE 特性曲線

Pressure Drop 壓力降

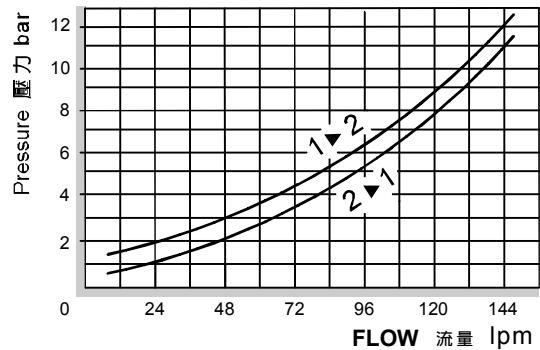

### ◆ SPECIFICATIONS 規格

Model Number 型式號碼	Maximum Pressure 最大壓力 bar	Maximum Flow 最大流量 lpm	Weight 重量 Kg
VSE12-22	350 (5076 psi)	150 (39.63 gpm)	0.66 (1.46 lbs)
Fluid Type 流體型式		ISO VG 32, 46, 68	
Viscosity 黏性 cSt		10~400 (59~1854 SSU)	
Operating Temperature 操作溫度 °C		-30~100 (-22~212°F)	
Contamination Level 污染標準		ISO4406. 21/19/16 NAS1638,10	

### ◆ HOW TO ORDER 編號說明

1	2	3	4	5	6
VSE	12	—	22	—	A2 — X — Y

#### 1 VALVE SERIES 系列名稱

VSE=Cartridge Type Solenoid Operated Check Valves 插入式電磁止逆閥

#### 2 SUBPLATE MOUNTING SIZE 稱呼口徑

12: E-021  
Cavity 孔口: CSE 021-2N  
See Page Appendixes-A\_001  
見附錄A\_001 頁面

#### 3 CONTROL PORT(S) 動作形式

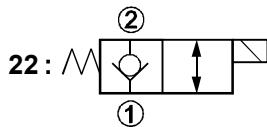

#### 4 TYPE OF COIL 線圈類型

Non: Without Coil 無記號:無線圈  
A1 : RAC110V 60/50HZ D1 : DC12V  
A2 : RAC220V 60/50HZ D2 : DC24V

#### 5 WIRING TYPE 接線型式

Non: WIRING BOX TYPE (DIN) 無:接線盒式 (DIN) X: DOUBLE LEAD 雙接線方式



※ For more technical information of wiring typt please refer to the appendixes-D or contact with us .  
接線型式的詳細技術資料請查附錄-D或與我們聯繫.

#### 6 ADJUSTMENT OPTION 調整選擇

Non	
Non:Standard 無記號:標準型	
Y	
Y: Twist Style Manual Override 旋緊型-手動操作復位	

### ◆ DIMENSIONS 外型尺寸圖

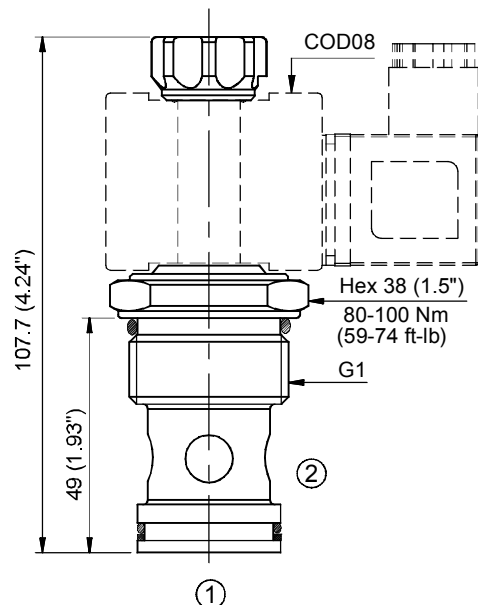

A  
032  
VSE