

### MODEL 型式

VSV08-20

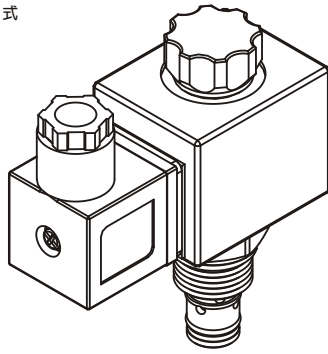

### PERFORMANCE 特性曲線

Pressure Drop 壓力降

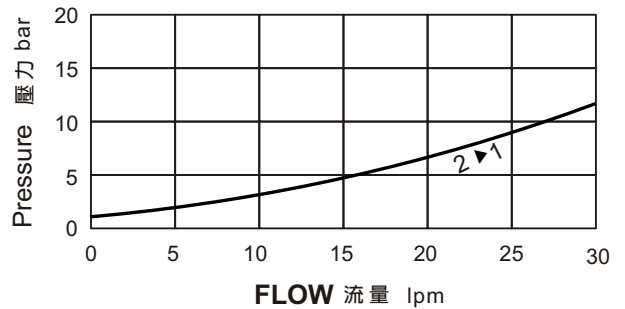

### SPECIFICATIONS 規格

Model Number 型號號碼	Maximum Resist Pressure 最大耐壓 bar	Maximum Operating Pressure 最大工作壓力 bar	Maximum Flow 最大流量 lpm	Rated Flow 額定流量 lpm	Weight 重量 Kg
VSV08-20MF	350 (5076 psi)	250 (3626 psi)	35 (9.25 gpm)	30 (7.93 gpm)	0.45 (0.99 lbs)
VSV08-20	350 (5076 psi)	350 (5076 psi)			
Fluid Type 流體型式			ISO VG 32, 46, 68		
Viscosity 黏性 cSt			10~400 (59~1854 SSU)		
Operating Temperature 操作溫度 °C			-30~100 (-22~212°F)		
Contamination Level 污染標準			ISO4406. 21/19/16 NAS1638,10		

### HOW TO ORDER 編號說明

<b>1</b>	<b>2</b>	<b>3</b>	<b>4</b>	<b>5</b>	<b>6</b>
VSV	08	—	20	—	A2 — X — Y

#### 1 VALVE SERIES 系列名稱

VSV=Cartridge Type Solenoid Operated  
Check Valves 插入式電磁止逆閥

#### 2 SUBPLATE MOUNTING SIZE 稱呼口徑

Size:08  
Cavity 孔口: CS08-2N  
See Page Appendixes-A\_001  
見附錄A\_001 頁面

#### 3 CONTROL PORT(S) 動作形式



#### 4 TYPE OF COIL 線圈類型

Non: Without Coil 無記號:無線圈  
A1 : RAC110V 60/50HZ      D1 : DC12V  
A2 : RAC220V 60/50HZ      D2 : DC24V

#### 5 WIRING TYPE 接線型式

Non: WIRING BOX TYPE (DIN) 無:接線盒式 (DIN)      X: DOUBLE LEAD 雙接線方式



※ For more technical information of wiring typt please refer to the appendixes-D or contact with us .  
接線型式的詳細技術資料請查附錄-D或與我們聯繫.

### 6 ADJUSTMENT OPTION 調整選擇

<b>Non</b> Non:Standard 無記號:標準型		<b>Z</b> Z:Cable Operated Pull Style Override 軟軸控型 - 拉動式操作復位	 M8xP1.25
<b>Y</b> Y:Twist Style Manual Override 旋緊型 - 手動操作復位		<b>P</b> P:Hand Operated Pull Style Override 手控型 - 拉動式操作復位	

### DIMENSIONS 外型尺寸圖

