

◆ MODEL 型 式

VSV08-215

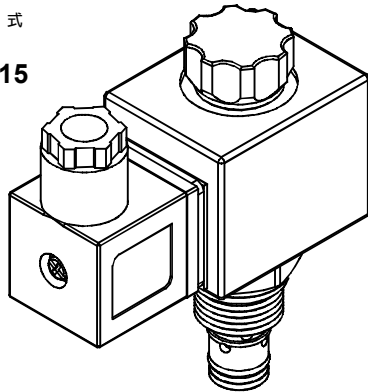

◆ PERFORMANCE 特性曲線

Pressure Drop 壓力降

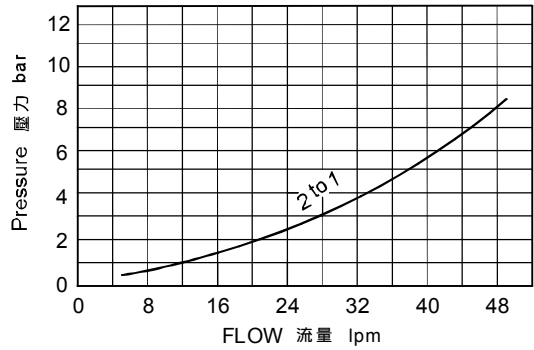

◆ SPECIFICATIONS 規 格

Model Number 型式號碼	Maximum Resist Pressure 最大耐壓 bar	Maximum Operating Pressure 最大工作壓力 bar	Maximum Flow 最大流量 lpm	Rated Flow 額定流量 lpm	Weight 重量 Kg
VSV08-215MF	350 (5076 psi)	250 (3626 psi)	35 (9.25 gpm)	30 (7.93 gpm)	0.45 (0.99 lbs)
VSV08-215	350 (5076 psi)	350 (5076 psi)			
Fluid Type 流體型式			ISO VG 32, 46, 68		
Viscosity 黏性 cSt			10~400 (59~1854 SSU)		
Operating Temperature 操作溫度 °C			-30~100 (-22~212°F)		
Contamination Level 污染標準			ISO4406. 21/19/16 NAS1638,10		

◆ HOW TO ORDER 編號說明

1	2	3	4	5	6
VSV	08	— 215 —	A2	— X —	Y

1 VALVE SERIES 系列名稱

VSV=Cartridge Type Solenoid Operated
Check Valves 插入式電磁止逆閥

2 SUBPLATE MOUNTING SIZE 稱呼口徑

Size:08
Cavity 孔口: CS08-2N
See Page Appendixes-A_001
見附錄A_001 頁面

3 CONTROL PORT(S) 動作形式



4 TYPE OF COIL 線圈類型

Non: Without Coil 無記號:無線圈
A1 : RAC110V 60/50HZ D1 : DC12V
A2 : RAC220V 60/50HZ D2 : DC24V

5 WIRING TYPE 接線型式

Non:WIRING BOX TYPE(DIN) X: DOUBLE LEAD
無:接線盒式 (DIN) 雙接線方式

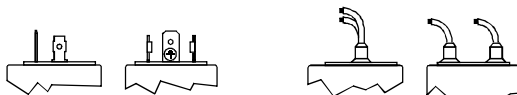

※ For more technical information of wiring typt please refer to the appendixes-D or contact with us .
接線型式的詳細技術資料請查附錄-D或與我們聯繫.

6 ADJUSTMENT OPTION 調整選擇

Non Non:Standard 無記號:標準型		S S:Twist Style Manual Override 旋緊型- 手動操作復位	
M M:Push and Twist Style Manual Override 推壓扭轉型- 手動操作復位		Y Y:Push Style Manual Override 推壓型- 手動操作復位	

◆ DIMENSIONS 外型尺寸圖

