

◆ **MODEL 型 式**  
VSV08-22

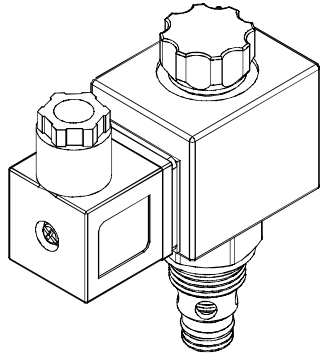

◆ **PERFORMANCE 特性曲線**

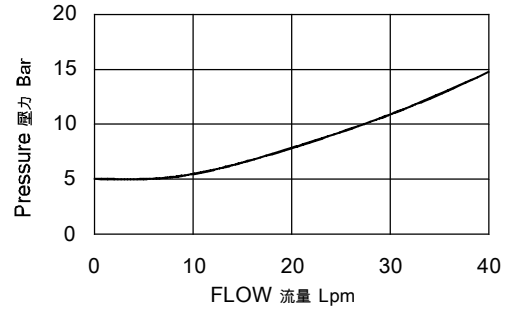

◆ **SPECIFICATIONS 規 格**

Model Number 型式號碼	Maximum Pressure 最大壓力 bar	Maximum Flow 最大流量 lpm	Weight 重量 Kg
VSV08-22	350 (5076 psi)	40 (10.57 gpm)	0.45 (0.99 lbs)
<b>Fluid Type 流體型式</b>		ISO VG 32, 46, 68	
<b>Viscosity 黏性 cSt</b>		10~400 (59~1854 SSU)	
<b>Operating Temperature 操作溫度 °C</b>		-30~100 (-22~212°F)	
<b>Contamination Level 污染標準</b>		ISO4406. 20/18/15 NAS1638. 9	

◆ **HOW TO ORDER 編號說明**

<b>1</b>	<b>2</b>	<b>3</b>	<b>4</b>	<b>5</b>	<b>6</b>
VSV	08	—	22	—	A2 — X — Y

**1 VALVE SERIES 系列名稱**  
VSV=Cartridge Type Solenoid Operated  
Check Valves 插入式電磁止逆閥

**2 SUBPLATE MOUNTING SIZE 稱呼口徑**  
Size:08  
Cavity 孔口 : CS08-2N  
See Appendixes-A 見附錄A  
For Manifold See Appendixes-B 油路板見附錄B

**3 CONTROL PORT(S) 動作形式**

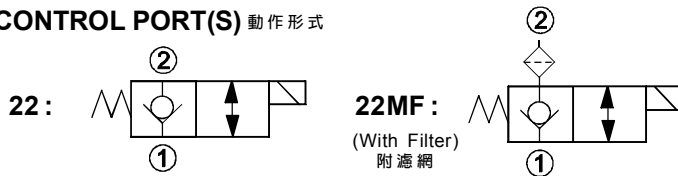

**4 TYPE OF COIL 線圈類型**

**Non** : Without Coil 無記號:無線圈  
**A1** : RAC110V 60/50HZ **D1** : DC12V  
**A2** : RAC220V 60/50HZ **D2** : DC24V

**5 WIRING TYPE 接線型式**

**Non**: WIRING BOX TYPE (DIN) 無:接線盒式 (DIN) **X** : DOUBLE LEAD 雙接線方式



※ For more technical information of wiring typt please refer to the appendixes-D or contact with us .  
接線型式的詳細技術資料請查附錄-D或與我們聯繫。

**6 ADJUSTMENT OPTION 調整選擇**

<b>Non</b> Non:Standard 無記號:標準型	
<b>Y</b> Y:Twist Style Manual Override 旋緊型— 手動操作復位	
<b>Z</b> Z:Cable Operated Pull Style Override 軟軸控型— 拉動式操作復位	

◆ **DIMENSIONS 外型尺寸圖**

