

SOLENOID OPERATED CARTRIDGE VALVES

插入式電磁閥

VSV SERIES CARTRIDGE TYPE SOLENOID OPERATED CHECK VALVES (SPEED)

vsv 系列插入式電磁止逆閥(快速型)

◆ MODEL 型式

VSV08-22S

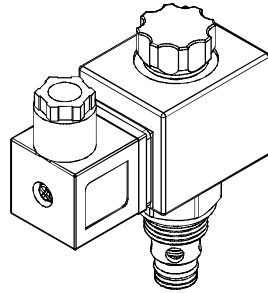

◆ PERFORMANCE 特性曲線

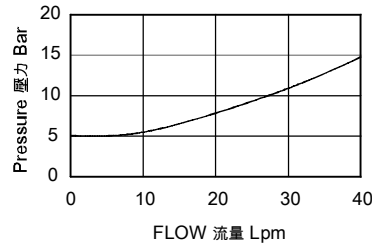

◆ SPECIFICATIONS 規格

Model Number 型式號碼	Maximum Pressure 最大壓力 bar	Maximum Flow 最大流量 lpm	Weight 重量 Kg
VSV08-22S	350 (5076psi)	40 (10.57gpm)	0.45 (0.99 lbs)
Fluid Type 流體型式		ISO VG 32, 46, 68	
Viscosity 黏性 cSt		10~400 (59~1854 SSU)	
Operating Temperature 操作溫度 °C		-30~100 (-22~212°F)	
Contamination Level 污染標準		ISO4406. 21/19/16 NAS1638,10	

◆ HOW TO ORDER 編號說明

1	2	3	4	5	6
VSV	08	— 22S —	A2 —	X —	Y

1 VALVE SERIES 系列名稱

VSV=Cartridge Type Solenoid Operated Check Valves (speed)
插入式電磁止逆閥(快速型)

2 SUBPLATE MOUNTING SIZE 稱呼口徑

Size : 08
Cavity 孔口:CS08-2N
See Page Appendixes-A_001
見附錄A_001 頁面

3 CONTROL PORT(S) 動作形式

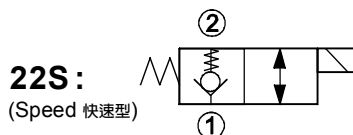

4 TYPE OF COIL 線圈類型

Non : Without Coil 無記號:無線圈
A1 : RAC110V 60/50HZ D1 : DC12V
A2 : RAC220V 60/50HZ D2 : DC24V

5 WIRING TYPE 接線型式

Non:WIRING BOX TYPE(DIN) X : DOUBLE LEAD
無:接線盒式(DIN) 雙接線方式



※ For more technical information of wiring typt please refer to the appendixes-D or contact with us .
接線型式的詳細技術資料請查附錄-D或與我們聯繫。

6 ADJUSTMENT OPTION 調整選擇

Non		Y	
Non:Standard 無記號:標準型		Y:Twist Style Manual Override 旋緊型— 手動操作復位	

◆ TECHNICAL DATA 技術數據

The only difference between this valve and the standard model is a spring placed between pilot section and poppet . 該閥與標準閥的唯一區別是在先導部份和提動閥之間的彈簧。
This design allows faster response times with very small flow or even virtually zero flow.
這樣的設計在低流量甚至零流量時實現更快的響應時間。
A pressure of approximately 5 bar (73 psi) is required to open the main poppet. 主閥的開啟壓力約為 5 bar (73 psi).

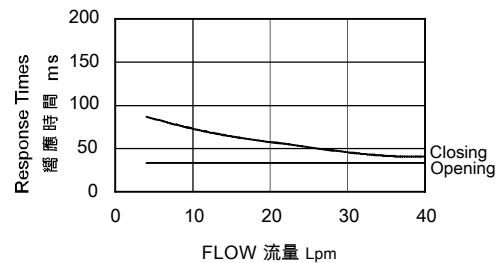

◆ DIMENSIONS 外型尺寸圖

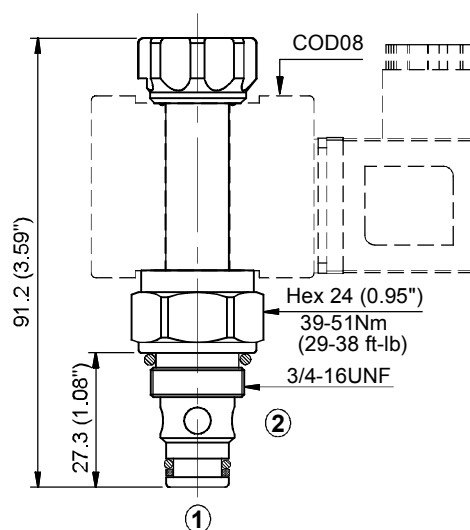

A
082
VSV