

◆ **MODEL** 型 式
VSV10-25

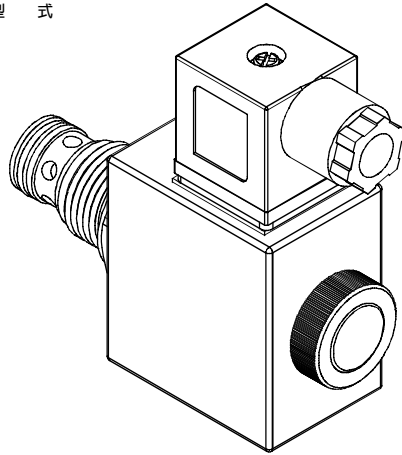

◆ **PERFORMANCE** 特性曲線

Test Conditions 測試條件
Oil Temperature 油溫度: 40°C (104°F)
Viscosity 黏性: 32 cSt (150 SSU)

Pressure Drop 壓力降

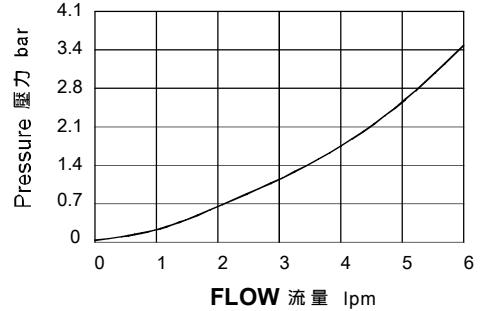

◆ **SPECIFICATIONS** 規 格

Model Number 型式號碼	Maximum Pressure 最大壓力 bar	Maximum Flow 最大流量 lpm	Weight 重量 Kg
VSV10-25	210 (3046psi)	20 (5.28gpm)	0.61 (1.34 lbs)
Fluid Type 流體型式		ISO VG 32, 46, 68	
Viscosity 黏性 cSt		10~400 (59~1854 SSU)	
Operating Temperature 操作溫度 °C		-30~100 (-22~212°F)	
Contamination Level 污染標準		ISO4406. 21/19/16 NAS1638,10	

◆ **HOW TO ORDER** 編號說明

1	2	3	4	5	6
VSV	10	—	25	—	A1 — X — *

1 VALVE SERIES 系列名稱

VSV=Cartridge Type Solenoid Operated
Check Valves 插入式電磁止逆閥

2 SUBPLATE MOUNTING SIZE 稱呼口徑

Size:10
Cavity 孔口: CS10-2N
See Page Appendixes-A_001
見附錄A_001 頁面

3 CONTROL PORT(S) 動作形式

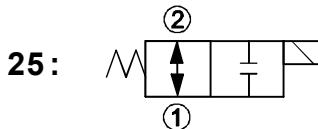

4 TYPE OF COIL 線圈類型

Non: Without Coil 無記號:無線圈
A1 : RAC110V 60/50HZ D1 : DC12V
A2 : RAC220V 60/50HZ D2 : DC24V

5 WIRING TYPE 接線型式

Non: WIRING BOX TYPE (DIN) X: DOUBLE LEAD
無:接線盒式 (DIN) 雙接線方式



※ For more technical information of wiring typt please refer to the appendixes-D or contact with us .
接線型式的詳細技術資料請查附錄-D或與我們聯繫。

6 ADJUSTMENT OPTION 調整選擇

Non Non:Standard 無記號:標準型		Y Y:Twist Style Manual Override 旋緊型— 手動操作復位	
---------------------------------------	--	--	--

◆ **DIMENSIONS** 外型尺寸圖

