

◆ MODEL 型 式

VWE08-20

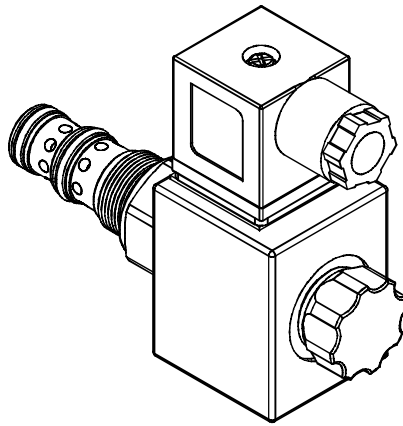

◆ SPECIFICATIONS 規 格

Model Number 型式號碼	Maximum Pressure 最大壓力 bar	Maximum Flow 最大流量 lpm	Weight 重量 Kg
VWE08-20	210 (3046 psi)	10 (2.64 gpm)	0.45 (0.99 lbs)
Fluid Type 流體型式		ISO VG 32, 46, 68	
Viscosity 黏性 cSt		10~400 (59~1854 SSU)	
Operating Temperature 操作溫度 °C		-30~100 (-22~212°F)	
Contamination Level 污染標準		ISO4406. 21/19/16 NAS1638,10	

◆ HOW TO ORDER 編號說明

1	2	3	4	5
VWE	08	— 20 —	A1	— X

1 VALVE SERIES 系列名稱

VWE= Spool 3-Way 2-Position
閥蕊 三方向 二方位

2 SUBPLATE MOUNTING SIZE 稱呼口徑

Size:08
Cavity 孔口: CS08-3N
See Page Appendixes-A_002
見附錄A_002 頁面

3 CONTROL PORT(S) 動作形式

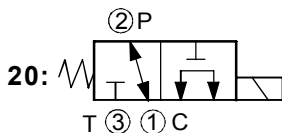

4 TYPE OF COIL 線圈類型

Non: Without Coil 無記號:無線圈
A1 : RAC110V 60/50HZ D1 : DC12V
A2 : RAC220V 60/50HZ D2 : DC24V

5 WIRING TYPE 接線型式

Non: WIRING BOX TYPE (DIN) X : DOUBLE LEAD
無: 接線盒式 (DIN) 雙接線方式



※ For more technical information of wiring type please refer to the appendixes-D or contact with us .
接線型式的詳細技術資料請查附錄-D或與我們聯繫.

◆ DIMENSIONS 外型尺寸圖

